

Kelly Opto-Isolated Series/Sep-Ex Motor Controller with Regen User's Manual

HSR07601

HSR07801

HSR12401

HSR12601

HSR12901

HSR14301

HSR14501

HSR14701

HSE12601

HSE12801

HSE12101

HSE12121

HSE14451

HSE14601

HSE14801

HSE14101

Contents

- Chapter 1 Introduction..... 2
 - 1.1 Overview..... 2
- Chapter 2 Main Features and Specifications..... 3
 - 2.1 General functions..... 3
 - 2.2 Features..... 4
 - 2.3 Specifications..... 4
- Chapter 3 Wiring and Installation..... 5
 - 3.1 Mounting the Controller..... 5
 - 3.2 Connections..... 8
 - 3.2.1 Panels of HSR/HSE Motor Controller..... 8
 - 3.2.2 HSR Series Motor Controller Wiring Diagram..... 11
 - 3.2.3 HSE Sep-Ex Motor Controller with Regen Wiring Diagram..... 12
 - 3.2.4 Communication Port..... 13
 - 3.3 Installation Checklist..... 13
- Chapter 4 Maintenance..... 14
 - 4.1 Cleaning..... 14
 - 4.2 Configuration..... 14
- Table 1: LED CODES..... 15
- Contact Us:..... 16

Chapter 1 Introduction

1.1 Overview

This manual introduces the features, installation and maintenance of the Kelly High Power Opto-isolated Series/Sep-Ex Motor Controllers with Regen. Read the manual carefully and thoroughly before using the controller. If you have any questions, please contact the support center of Kelly Controls, LLC.

Kelly's programmable motor controllers provide efficient, smooth and quiet controls for high power electric vehicles like forklifts, hybrid vehicles, as well as electric boats and industrial motor speed control. It uses high power MOSFET's and, high frequency and fast PWM to achieve efficiencies of up to 99% in most cases. A powerful microprocessor brings in comprehensive and precise control to the controllers. It also allows users to adjust parameters, conduct tests, and obtain diagnostic information quickly and easily.

Chapter 2 Main Features and Specifications

2.1 General functions

- (1) Extended fault detection and protection. Red LED flashing pattern indicates the fault sources, and Green LED indicates normal operation. Controller will shut down in some fault conditions.
- (2) Built-in current loop and over current protection.
- (3) Current cutback at low temperature and high temperature to protect battery and controller. The current begins to ramp down at 90° C case temperature, shutting down at 100° C.
- (4) Configurable motor over-temperature detection and protection with the recommended thermistor KTY83-122.
- (5) Monitoring battery voltage. It will stop driving if the battery voltage is too high and it will progressively cut back motor drive power as battery voltage drops until it cuts out altogether at the preset "Low Battery Voltage" setting.
- (6) Monitoring battery recharging voltage during regenerative braking, progressively cutting back current as battery voltage rises then cutting off regen altogether when voltage goes too high.
- (7) Multifunctional and configurable 3 switch inputs: brake switch, reversing switch, throttle or forward switch. Default to active-low, customizable active-high.
- (8) 3 analog 0-5V inputs that default to throttle input, brake input and motor temperature input.
- (9) Configurable and programmable with a host computer through RS232 or USB. Provide free GUI which can run on Windows XP/2000, Windows 7 and Vista(recommend using Kelly Standard USB To RS232 Converter).
- (10) Maximum reverse speed is configurable to half of the maximum forward speed.
- (11) Maximum reverse current is configurable to half of the maximum forward current.
- (12) Configurable limit for motor current
- (13) Capable of connecting to Kelly Ampmeter: positive to 5V power supply of controller, negative to J1-2.
- (14) Provision of a +5 volt output to supply various kinds of sensors, including Hall effect type.
- (15) Pulsed reverse alarm output.
- (16) Main contactor driver. Cutting off the power if any fault is detected.
- (17) Optional CAN Bus.
- (18) Optional electronic unidirectional or bidirectional field drive for HSE controller.
- (19) Customizable field current for HSE controller, less than 120A. Field driving capability is equivalent to armature for HSR controller.

Caution! Regeneration has braking effect but does not replace the function of a mechanical brake. A mechanical brake is required to stop your vehicle. Regen IS NOT a safety feature! Controller may stop regen, without warning, to protect itself or the battery(it won't protect you!).

2.2 Features

- Opto-isolated technology achieves stability.
- Intelligence with powerful microprocessor.
- Synchronous rectification, ultra low drop, and fast PWM to achieve very high efficiency.
- Voltage monitoring on voltage source 5V.
- Hardware over current protection.
- Hardware over voltage protection.
- Current limit and torque control.
- Low EMC.
- LED fault code.
- Battery protection: current cutback, warning and shutdown at configurable high and low battery voltage.
- Rugged aluminum housing for maximum heat dissipation and harsh environment. Support fan or water cooling.
- Rugged high current terminals, and rugged aviation connectors for small signal.
- Thermal protection.
- Configurable current or voltage mode for HSE field driver to achieve flexibility.
- Configurable high pedal protection: Disable operation if power up with high throttle.
- Brake switch is used to start regen.
- 0-5V brake signal is used to command regen current.
- Standard PC/Laptop computer is used to do programming. No special tools needed.
- Provide free User Program. Easy to use. No cost to customers.
- Current multiplication: Take less current from battery, output more current to motor.
- Easy installation: 1-4V "Hall Active" throttle or "3 Wire" potentiometer(<100K) can work.

2.3 Specifications

- Frequency of Operation: 16.6kHz.
- Standby Battery Current depending on the model: usually less than 2mA.
- Controller input power, PWR: less than 10W.
- Controller supply voltage range, PWR, 8 to 30V
- Configurable battery voltage range, B+. Max operating range: 18V to 180V(depending on the model).
- Standard Throttle Input: 0-5 Volts(3-wire resistive pot), 1-4 Volts(hall active throttle).
- Analog Brake and Throttle Input: 0-5 Volts. 0-5V signal is produced by 3-wire pot.
- Reverse Alarm, Main Contactor Coil Driver, Meter.
- Full Power Temperature Range: 0° C to 50° C (controller case temperature).
- Operating Temperature Range: -30° C to 90° C , 100° C shut down (controller case temperature).
- Motor Current Limit, 1 minutes: 300-1200A, depending on the model.
- Motor Current Limit, continuous:135-540A, depending on the model.

Kelly HSR Series Motor Controller with Regen, HSE Sep-Ex Motor Controller with Regen						
Model	1 minutes current	continuous current	Nominal Voltage Range	Max operating voltage	Regen	Type
HSR07601	600A	270A	24V-72V	18V-90V	Yes	Series
HSR07801	800A	360A	24V-72V	18V-90V	Yes	Series
HSR12401	400A	180A	24V-120V	18V-136V	Yes	Series
HSR12601	600A	270A	24V-120V	18V-136V	Yes	Series
HSR12901	900A	405A	24V-120V	18V-136V	Yes	Series
HSR14301	300A	135A	24V-144V	18V-180V	Yes	Series
HSR14501	500A	225A	24V-144V	18V-180V	Yes	Series
HSR14701	700A	315A	24V-144V	18V-180V	Yes	Series
HSE12601	600A	270A	24V-120V	18V-136V	Yes	Sep-Ex
HSE12801	800A	360A	24V-120V	18V-136V	Yes	Sep-Ex
HSE12101	1000A	450A	24V-120V	18V-136V	Yes	Sep-Ex
HSE12121	1200A	540A	24V-120V	18V-136V	Yes	Sep-Ex
HSE14451	450A	200A	24V-144V	18V-180V	Yes	Sep-Ex
HSE14601	600A	270A	24V-144V	18V-180V	Yes	Sep-Ex
HSE14801	800A	360A	24V-144V	18V-180V	Yes	Sep-Ex
HSE14101	1000A	450A	24V-144V	18V-180V	Yes	Sep-Ex

Chapter 3 Wiring and Installation

3.1 Mounting the Controller

The controller can be oriented in any position which should be as clean and dry as possible, and if necessary, shielded with a cover to protect it from water and contaminants.

To ensure full rated output power, the controller should be fastened to a clean, flat metal surface with four or six screws. A thermal joint compound can be used to improve heat conduction from the case to the mounting surface. The case outline and mounting holes' dimensions are shown in Figure 1 and 2.

Caution:

- **RUNAWAYS** — Some conditions could cause the vehicle to run out of control. Disconnect the motor, or jack up the vehicle, and get the drive wheels off the ground before attempting any work on the motor control circuitry.
- **HIGH CURRENT ARCS** — Electric vehicle batteries can supply very high power, and arcs can occur if they are short circuit. Always turn off the battery circuit before working on the motor control circuit. Wear safety glasses, and use properly insulated tools to prevent short circuit

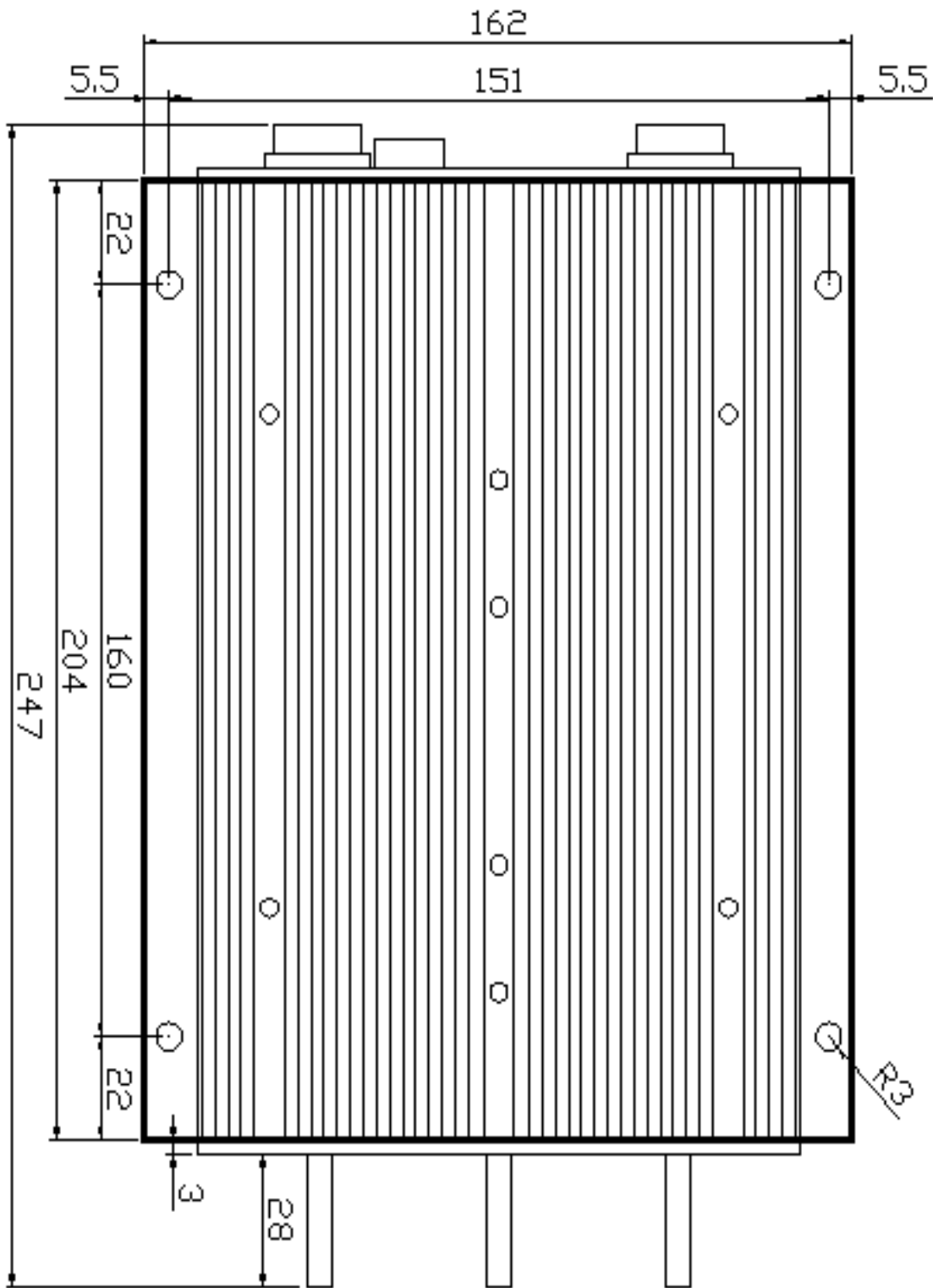

Figure 1: Height: 84 millimeters
 Length: 204 millimeters

Controller models with above dimension: HSR07601, HSR07801, HSR12401
 HSR12601, HSR14301, HSR14501
 HSE12601, HSE14451

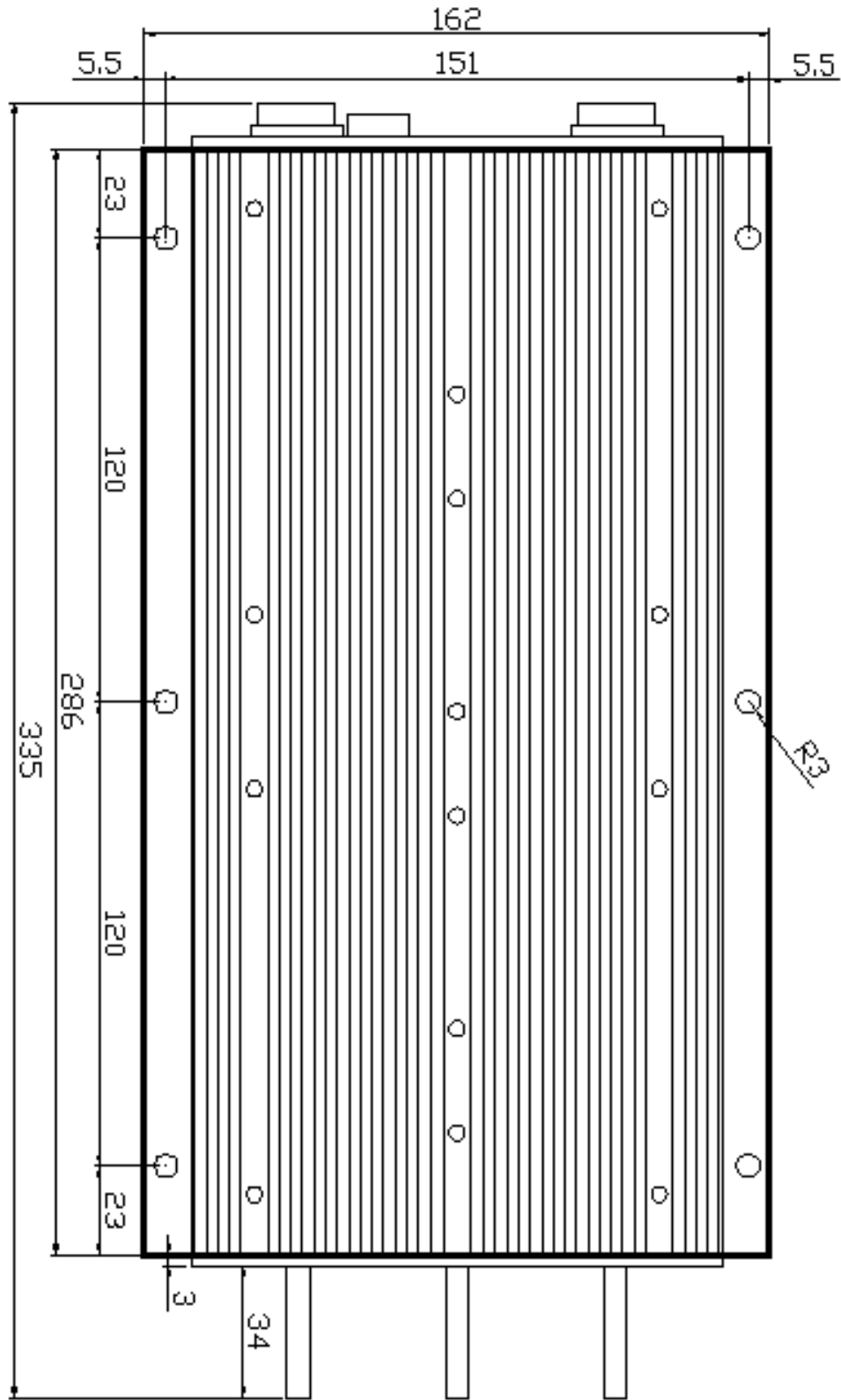

Figure 2: Height: 84 millimeters
Length: 286 millimeters

Controller models with above dimension: HSR12901, HSR14701,
HSE12801, HSE12101, HSE12121, HSE14601, HSE14801, HSE14101

3.2 Connections

3.2.1 Panels of HSR Series Motor Controller and HSE Sep-Ex Motor Controller

Three or four metal bars and two plugs (J1, J2) are provided for connecting to the battery, motor and control signals in the front of the controller shown as Figure 3, 4 and Figure 5.

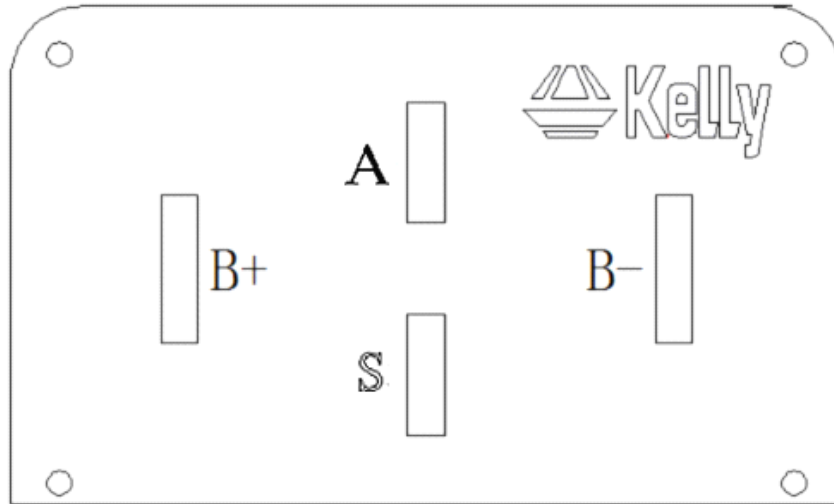

Figure 3: Front Panel of HSR Motor Controller

B+: battery positive and armature positive

B-: battery negative

A: armature negative

S: field negative

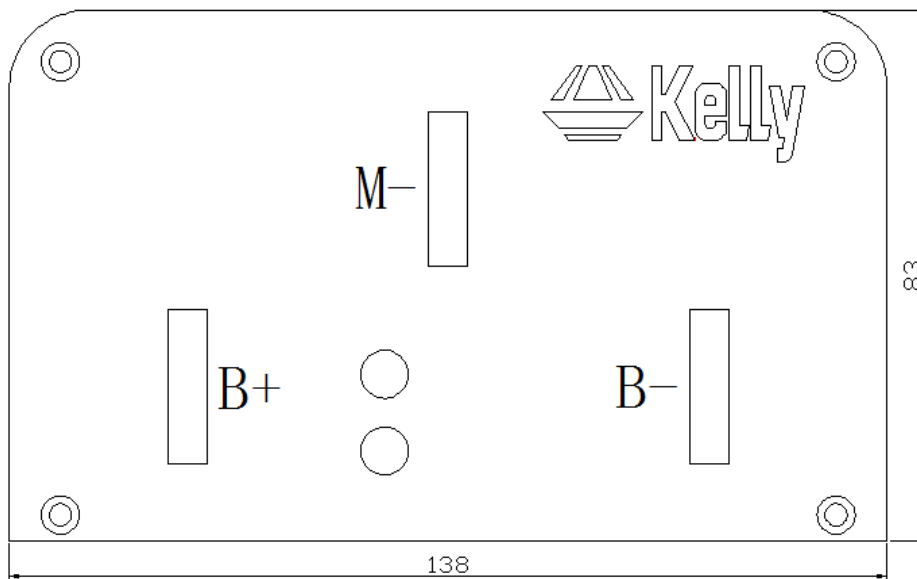

Figure 4: Front Panel of HSE Motor Controller

B+: battery positive and armature positive

B-: battery negative

M-: armature negative

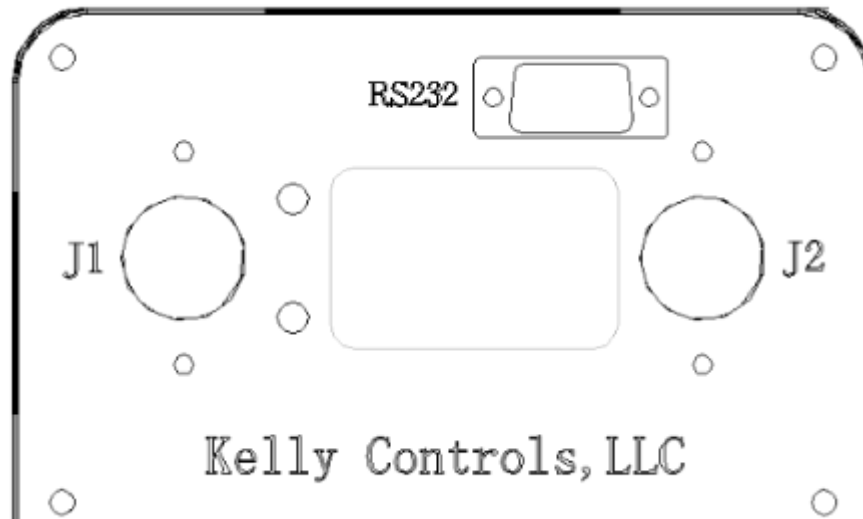

Figure 5: Back Panel of HSR/HSE Motor Controller

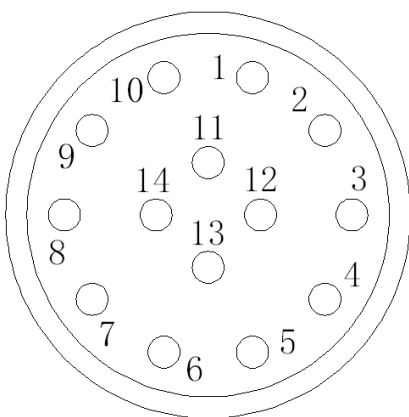

Figure 6: The Connecting Diagram of **J1** and **J2**

J1 Pin Definition

- 1- **Reserved**
- 2- **Kelly Current meter. <200mA**
- 3- **Main contactor driver. <2A**
- 4- **Alarm: To drive reverse beeper. <200mA**
- 5- **RTN: Signal return**
- 6- **Green LED: Running indication**
- 7- **RTN: Signal return**
- 8- **Reserved**
- 9- **Reserved**
- 10- **CAN bus high. Optional**
- 11- **CAN bus low. Optional**
- 12- **High level brake**
- 13- **RTN: Signal return, or power supply return**
- 14- **Red LED: Fault code.**

J2 Pin Definition

- 1- PWR: Controller power supply (input)
- 2- RTN: Signal return, or power supply return
- 3- RTN: Signal return
- 4- Motor temperature input. Demand use KTY83-122 Silicon temperature sensors.
- 5- Throttle analog input, 0-5V
- 6- Brake analog input, 0-5V
- 7- 5V: 5V supply output. <50mA
- 8- Throttle or forward switch input
- 9- Reversing switch input
- 10- Brake switch input
- 11- Reserved
- 12- Reserved
- 13- Reserved
- 14- RTN: Signal return

Notes: All RTN and GND pins are internally connected, but isolated from B-.

Caution:

- **Do not apply power until you are certain the controller wiring is correct and has been double checked. Wiring faults will damage the controller.**
- **Ensure that the B- wiring is securely and properly connected before applying power.**
- **The preferred connection of the system contactor or circuit breaker is in series with the B+ line.**
- **All contactors or circuit breakers in the B+ line must have precharge resistors across their contacts. Lack of even one of these precharge resistors may severely damage the controller at switch-on.**

3.2.2 HSR Series Motor Controller Wiring Diagram

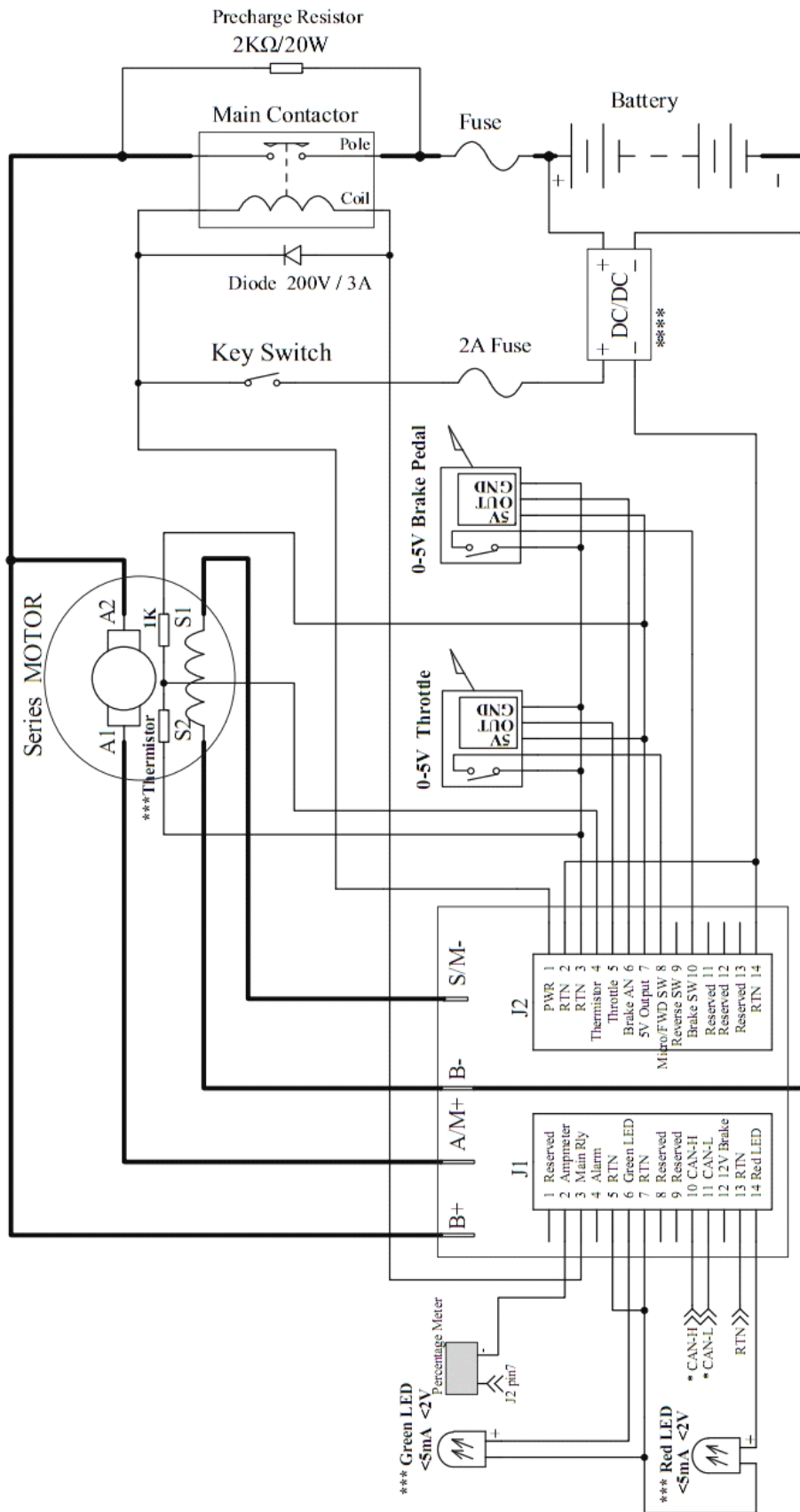

NOTE: Potentialmeter can be used to output 0-5V.
 Please securely wire B- before any other wiring. Never put contactor or break on B-. Don't connect RTN to B-.
 * CAN bus is deprecated by default.
 ** When you connect an external LED, the LED front panel brightness will be reduced.
 *** Thermistor is optional item. default to KTY83-122.
 ****12V Isolated DC/DC Converter Is Preferred.

Figure 7: HSR Series Motor Controller with Regen Wiring Diagram

3.2.3 HSE Sep-Ex Motor Controller with Regen Wiring Diagram

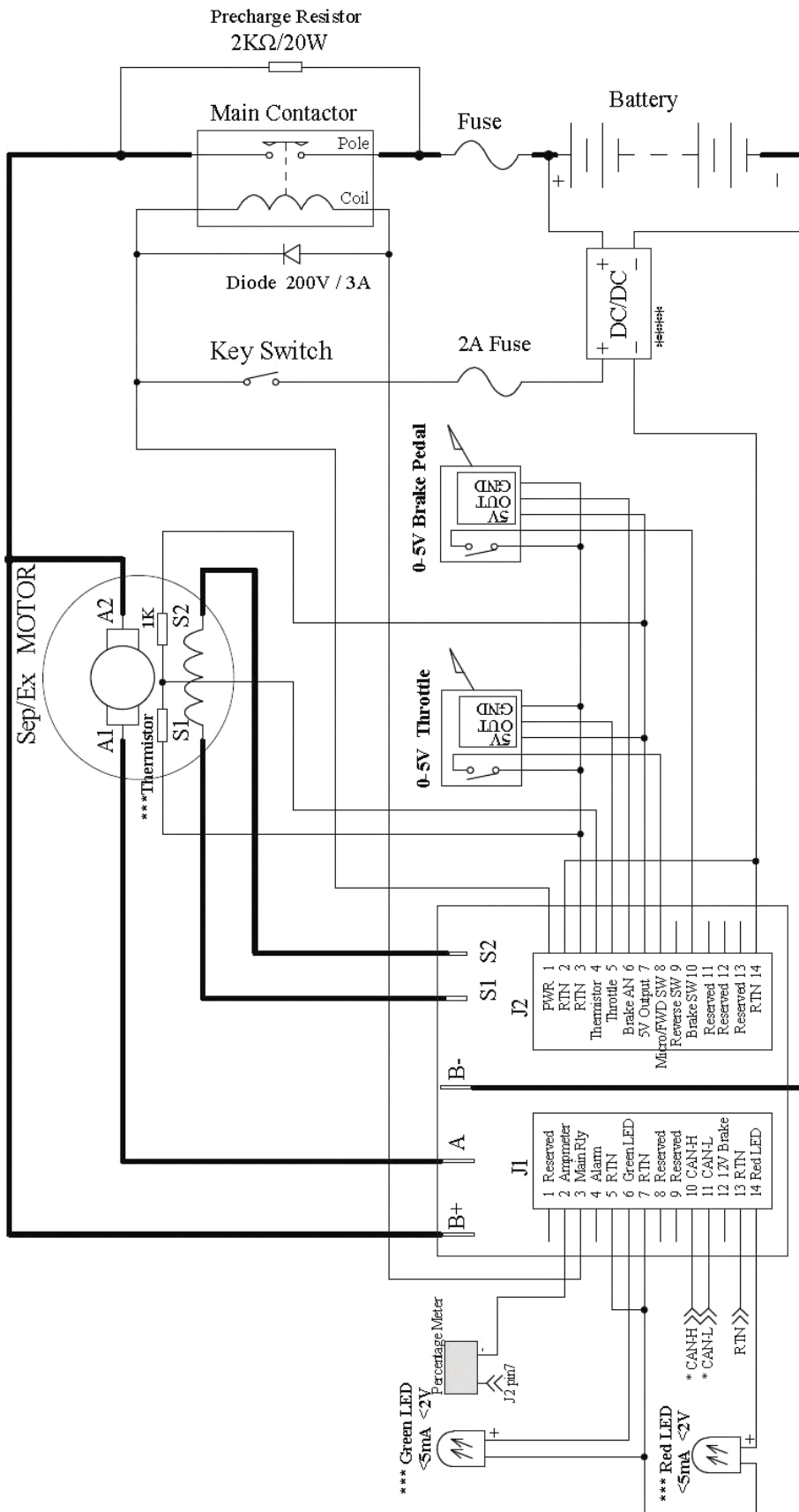

NOTE: Potentialmeter can be used to output 0-5V.
Please securely wire B- before any other wiring. Never put contactor or break on B-. Don't connect RTN to B-.
* CAN bus is deprecated by default.
** When you connect an external LED, the LED front panel brightness will be reduced.
*** Thermistor is optional item. default to KTY88-122.
**** 12V Isolated DC/DC Converter Is Preferred.

Figure 8: HSE Sep-Ex Motor Controller with Regen Wiring Diagram

3.2.4 Communication Port

A RS232 port of controller is provided to communicate with host computer for calibration and configuration.

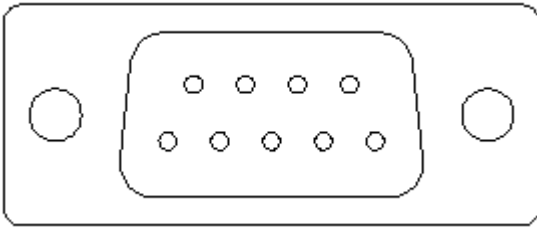

Figure 9: Standard RS232 Interface

3.3 Installation Checklist

Before operating the vehicle, complete the following checkout procedures. Use LED code as a reference as listed in Table 1.

Caution:

- **Put the vehicle up on blocks to get the drive wheels off the ground before beginning these tests.**
- **Do not allow anyone to stand directly in front of or behind the vehicle during the checkout.**
- **Make sure the PWR switch and the brake is off**
- **Use well-insulated tools.**

- Make sure the wire is connected correctly.
- Turn the PWR switch on. The Green LED stay on steadily and Red LED turns off when the controller operates normally. If this does not happen, check continuity of the PWR and return.
- The fault code will be detected automatically at restart.
- With the brake switch open, select a direction and operate the throttle. The motor should spin in the selected direction. Verify wiring or voltage and the fuse if it does not. The motor should run faster with increasing throttle. If not, refer to the Table 1 LED code, and correct the fault as determined by the fault code.
- Take the vehicle off the blocks and drive it in a clear area. It should have smooth acceleration and good top speed.

Chapter 4 Maintenance

There are no user-serviceable parts inside the controllers. Do not attempt to open the controller as this will void your warranty. However, periodic, exterior cleaning of the controller should be carried out.

The controller is a high powered device. When working with any battery powered vehicle, proper safety precautions should be taken that include, but are not limited to, proper training, wearing eye protection, avoidance of loose clothing, hair and jewelry. Always use insulated tools.

4.1 Cleaning

Although the controller requires virtually no maintenance after properly installation, the following minor maintenance is recommended in certain applications.

- Remove power by disconnecting the battery, starting with battery positive.
- Discharge the capacitors in the controller by connecting a load (such as a contactor coil or a horn) across the controller's B+ and B- terminals.
- Remove any dirt or corrosion from the bus bar area. The controller should be wiped down with a moist rag. Make sure that the controller is dry before reconnecting the battery.
- Make sure the connections to the bus bars, if fitted, are tight. To avoid physically stressing the bus bars use two, well-insulated wrenches.

4.2 Configuration

You can configure the controller with a host computer through either an RS232 or USB.

- Disconnect motor wiring from controller.
- Do not connect B+, throttle and so on. The controller may display fault code in some conditions, but it doesn't affect programming or configuration.
- Use a straight through RS232 cable or USB converter provided by Kelly to connect to a host computer. Provide a 8-30V supply to PWR (J2 pin1). Wire power supply return to any RTN pin, isolated from B-.

Download the free configuration software from:

<http://www.kellycontroller.com/support.php>

Caution:

• Make certain that the motor is disconnected before trying to run the Configuration Software!

• Configuration software will be regularly updated and published on the website. Please Update your Configuration Software regularly. You must uninstall the older version before updating.

Table 1: LED CODES

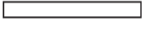
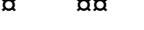
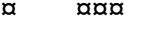
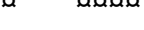
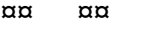
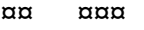
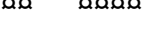
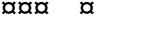
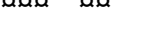
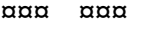
LED Code		Explanation	Solution
Green Off		No power or switched off	<ol style="list-style-type: none"> 1. Check if all wires are correct. 2. Check fuse and power supply.
Green On		Normal operation	That's great! You got solution!
1,2		Over voltage error	<ol style="list-style-type: none"> 1. Battery voltage is too high for the controller. Check battery volts and configuration. 2. Regeneration over-voltage. Controller will have cut back or stopped regen. 3. This only accurate to $\pm 2\%$ upon Overvoltage setting.
1,3		Low voltage error	<ol style="list-style-type: none"> 1. The controller will clear after 5 seconds if battery volts returns to normal. 2. Check battery volts & recharge if required.
1,4		Over temperature warning	<ol style="list-style-type: none"> 1. Controller case temperature is above 90°C. Current will be limited. Reduce controller loading or switch Off until controller cools down. 2. Clean or improve heatsink or fan.
2,2		Internal volts fault	<ol style="list-style-type: none"> 1. Measure that B+ & PWR are correct when measured to B- or RTN. 2. There may be excessive load on the +5V supply caused by too low a value of Regen or throttle potentiometers or incorrect wiring. 3. Controller is damaged. Contact Kelly about a warranty repair.
2,3		Over temperature	The controller temperature has exceeded 100 °C . The controller will be stopped but will restart when temperature falls below 80°C .
2,4		Throttle error at power-up	<ol style="list-style-type: none"> 1. The throttle got effective signal at key-on. Fault clears when throttle is released. You may reconfigure throttle effective range or foot switch 2. The acceleration throttle must be turned from zero up to high when the brake is released. Otherwise the controller will report this fault.
3,1		Frequent reset	May be caused by over-voltage, bad motor intermittent earthing problem, bad wiring, etc.
3,2		Internal reset	May be caused by some transient fault condition like a temporary over-current, momentarily high or low battery voltage. This can happen during normal operation.
3,3		Wrong connection of throttle	Valid throttle signal is between 1V-4V. Fault report because signal is less than 0.5V or greater than

			4.5V.
3,4	□□□ □□□□	Non-zero throttle on direction change	Controller won't allow a direction change unless the throttle or speed is at zero. Fault clears when throttle is released.
4,1	□□□□ □	Regen over-voltage	Motor drive is disabled if an over-voltage is detected during regen. The voltage threshold detection level is set during configuration.
4,2	□□□□ □□	Field error	1. Field did not reach the configured current. 2. Field circuit open. Please check field wiring.
4, 3	□□□□ □□□	Motor over-temperature	1. Motor temperature has exceeded the configured maximum. The controller will shut down until the motor temperature cools down. 2. Can change the temperature setting in configuration program.
<p>The Red LED flashes once at power on as a confidence check and then normally stays Off. "1, 2" means the Red flashes once and after a second pause, flashes twice. The time between two flashes is 0.5 second. The pause time between multiple flash code groups is two seconds.</p>			

Contact Us:

Kelly Controls, LLC

Home Page:

<http://www.kellycontroller.com>

E-mail:

support@kellycontroller.com

Phone:

(01) 224 637 5092