

Kelly Small Series/PM Motor Controller User's Manual

Devices Supported:

**KDS24050E
KDS24100
KDS24200
KDS24100E
KDS24200E
KDS36050E
KDS36100
KDS36200
KDS36100E
KDS36200E
KDS48050E
KDS48100
KDS48200
KDS48100E
KDS48200E
KDS72050E
KDS72100
KDS72100E
KDS72200
KDS72200E**

Content

Chapter 1 Introduction.....	2
1.1 Overview.....	2
Chapter 2 Main Features and Specifications.....	3
2.1 General functions.....	3
2.2 Features.....	3
2.3 Specifications.....	3
2.4 Models.....	4
Chapter 3 Wiring and Installation.....	6
3.1 Mounting the Controller.....	6
3.2 Connections.....	7
3.3 Installation Checkout.....	11
Chapter 4 Maintenance.....	12
4.1 Cleaning.....	12
Table 1: LED CODES.....	13
Contact Us:.....	14

Chapter 1 Introduction

1.1 Overview

This manual introduces the Kelly motor controllers' features, their installation and their maintenance. Read the manual carefully and thoroughly before using the controller. If you have any questions, please contact the support center of Kelly Controls, LLC.

Kelly's small series/PM motor controllers provide efficient, smooth and quiet controls for electric tricycles, electric motorcycles, pump motors, and industrial motor speed control. It uses high power MOSFET, synchronous rectification, and fast PWM to achieve high efficiency.

Chapter 2 Main Features and Specifications

2.1 General functions

- (1) Extended fault detection and protection. The LED flashing pattern indicates the fault sources.
- (2) Monitoring battery voltage. Stop driving if the battery voltage is too high or too low.
- (3) Built-in current loop and over current protection.
- (4) Configurable motor temperature protection range.
- (5) Current cutback at low temperature and high temperature to protect battery and controller. The current begins to ramp down at 90°C, shutting down at 100°C.
- (6) Maximum reverse speed is configurable to half of the maximum forward speed.
- (7) 0-5V throttle input.

2.2 Features

- Provision of a +5 volt output to supply various kinds of sensors, including Hall effect type.
- High current metal bar
- Small size
- Easy to use
- Used with PM or series motor
- Low cost
- Super high efficiency "E" model available
- Intelligence with powerful microprocessor.
- Synchronous rectification, ultra low drop, and fast PWM to achieve very high efficiency.
- Voltage monitoring on voltage source 12V and 5V.
- Current control loop.
- Hardware over current protection.
- Support torque mode operation.
- Low EMC.
- Battery protection: current cutback, warning and shutdown at configurable high and low battery voltage.
- Rugged aluminum housing for maximum heat dissipation and harsh environment.
- Rugged high current terminals, and aviation connectors for small signal.
- Thermal protection: current cut back, warning and shutdown at high temperature.
- Configurable high pedal protection: Disable operation if power up with high throttle.

2.3 Specifications

- Main Contactor Coil Drive, 2A.
- 5V Supply Output, 30mA.
- Frequency of Operation: 16.6kHz.
- Standby Current: less than 3mA.
- Standard Throttle Input: 0-5 Volts(3-wire resistive pot), 1-4 Volts(hall active throttle).
- Meter/Alarm output: 100mA.
- Full Power Operating Temperature Range: 0°C to 50°C (controller case temperature).

- Operating Temperature Range: -30°C to 90°C, 100°C shutdown (controller case temperature).
- Peak Current, 1 minute: 50- 200A, depending on the model.
- Continuous current: 30-120A, depending on the model.

2.4 Models

The naming regulations of the motor controller model:

KDS36200E

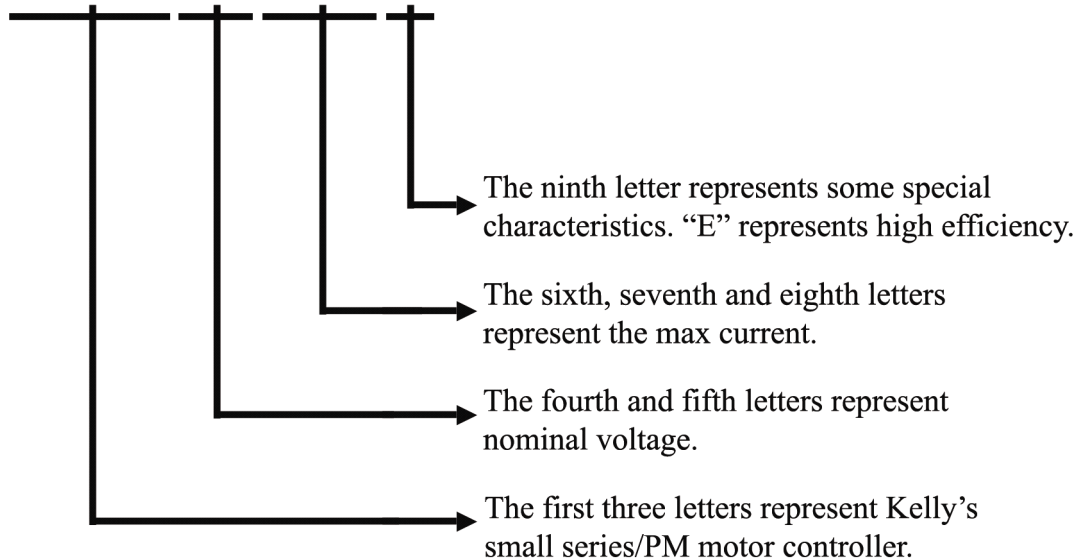

Kelly Small DC Motor Controller			
Model	1 Minute Current(Amp)	Continuous Current(Amp)	Voltage(Volt)
KDS24050E	50	30	12-24
KDS24100	100	40	12-24
KDS24200	200	80	12-24
KDS24100E	100	60	12-24
KDS24200E	200	120	12-24
KDS36050E	50	30	24-36
KDS36100	100	40	24-36
KDS36200	200	80	24-36
KDS36100E	100	60	24-36
KDS36200E	200	120	24-36
KDS48050E	50	30	24-48
KDS48100	100	40	24-48
KDS48200	200	80	24-48
KDS48100E	100	60	24-48
KDS48200E	200	120	24-48
KDS72050E	50	30	24-72
KDS72100	100	40	24-72
KDS72100E	100	60	24-72
KDS72200	200	80	24-72
KDS72200E	200	120	24-72

- 1.24V model: range of the max operating voltage is 8-30V.
 2.36V model: range of the max operating voltage is 18-45V.
 3.48V model: range of the max operating voltage is 18-60V.
 4.72V model: range of the max operating voltage is 18-90V.

Chapter3 Wiring and Installation

3.1 Mounting the Controller

The controller can be oriented in any position which should be as clean and dry as possible, and if necessary, shielded with a cover to protect it from water and contaminants.

To ensure full rated output power, the controller should be fastened to a clean, flat metal surface with four screws. A thermal joint compound can be used to improve heat conduction from the case to the mounting surface. The case outline and mounting holes' dimensions are shown in Figure 1.

Caution:

- **RUNAWAYS** — Some conditions could cause the motor to run out of control. Disconnect the motor, or jack up the vehicle, and get the drive wheels off the ground before attempting any work on the motor control circuitry.
- **HIGH CURRENT ARCS** — Electric vehicle batteries can supply very high power, and arcs can occur if they are short circuit. Always turn off the battery circuit before working on the motor control circuit. Wear safety glasses, and use properly insulated tools to prevent short circuit.

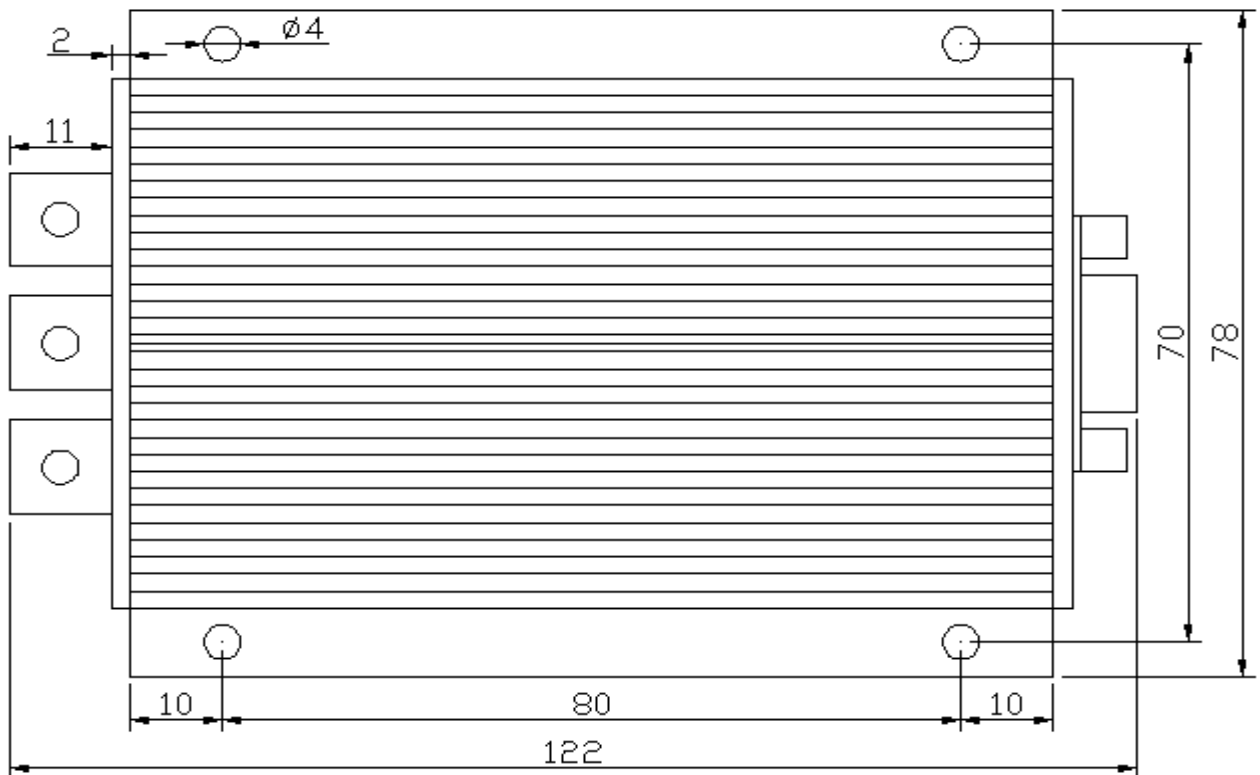

Tall: 41mm

Figure 1: mounting holes' dimensions (dimensions in millimeters)

3.2 Connections

3.2.1 Front Panel of Serial or PM Motor Controller:

3 metal bars are provided for connecting to the battery and motor in the front of the controller shown as Figure 2.

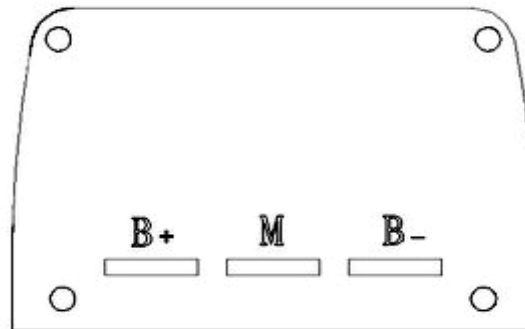

Figure 2: Front panel of Serial or PM Motor Controller

M: output to armature negative

B+: battery positive and armature positive

B-: battery negative

Caution:

- **Do not apply power until you are certain the controller wiring is correct and has been double checked. Wiring faults will damage the controller.**
 - **Ensure that the B- wiring is securely and properly connected before applying power.**
 - **The preferred connection of the system contactor or circuit breaker is in series with the B+ line.**
 - **All contactors or circuit breakers in the B+ line must have precharge resistors across their contacts.**
- Lack of even one of these precharge resistors may severely damage the controller at switch-on.**

3.2.2 Back Panel of Serial or PM Motor Controller:

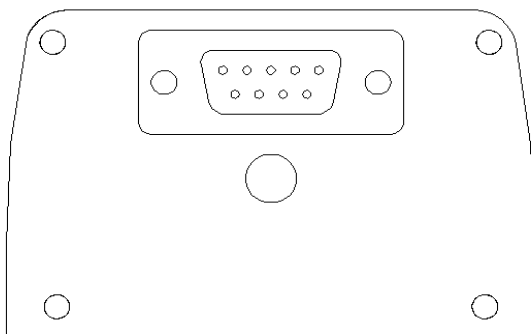

Figure 3: Back Panel and SCI Port

A SCI port is provided to communicate with RS232 of host computer for calibration and configuration. Please note only a special SCI Converter provided by Kelly Controls can be used. Please use straight RS232 cable to connect with PC



Figure 4: SCI Converter

Download the free configuration software from:

<http://www.kellycontroller.com/support.php>

Caution:

- **Make certain that the motor is disconnected before trying to run the Configuration Software!**
- **Configuration software will be regularly updated and published on the website. Please Update your Configuration Software regularly. You must uninstall the older version before updating.**

Figure 5: Definition of Controller's junction

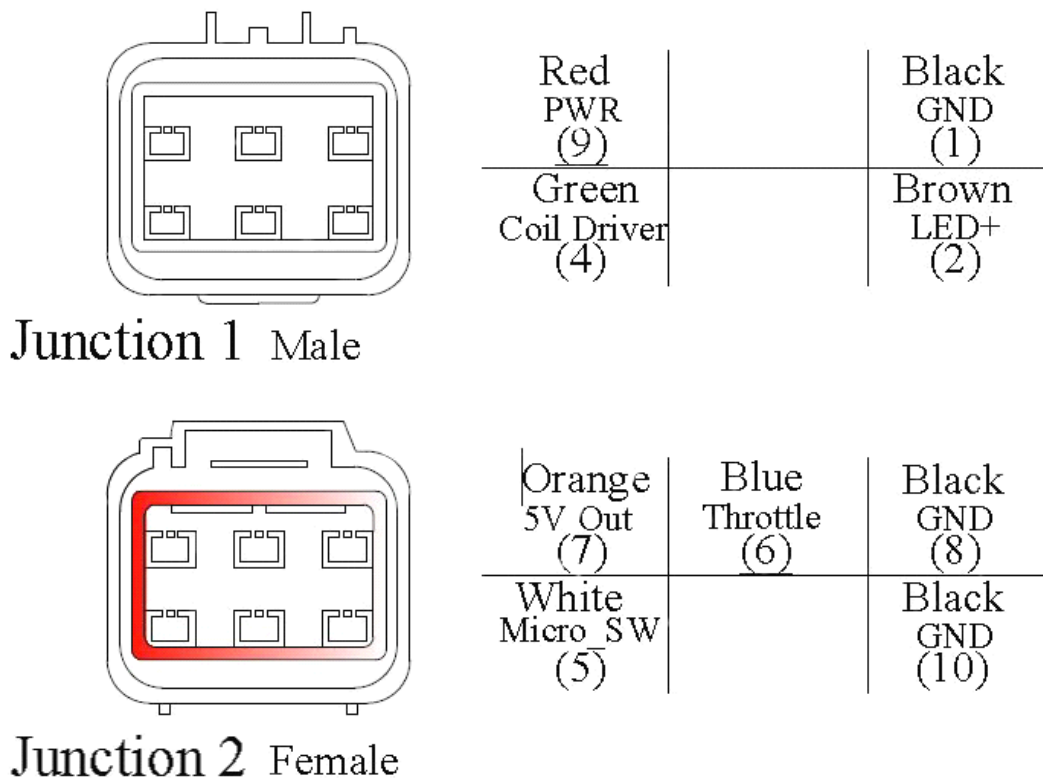

(9)PWR(red): Controller power supply, usually to key switch.

(1)GND(black): LED cathode and sensor return.

(4)Contactor Coil Driver(green): It's a low side driver. Please use PWR as the coil high side.

(2)LED(brown): To anode of LED.

(7)Throttle 5V power source(orange): 0-5V throttle power input.

(6)Throttle(blue): 0-5V throttle input.

(8)GND(black): TPS return and switch ground.

(5)Micro_SW (white): Close to GND to activate. Default as throttle switch.

Notes: All of the above GND pins are internally connected.

3.2.3 Standard Wiring of Series and PM Motor Controller

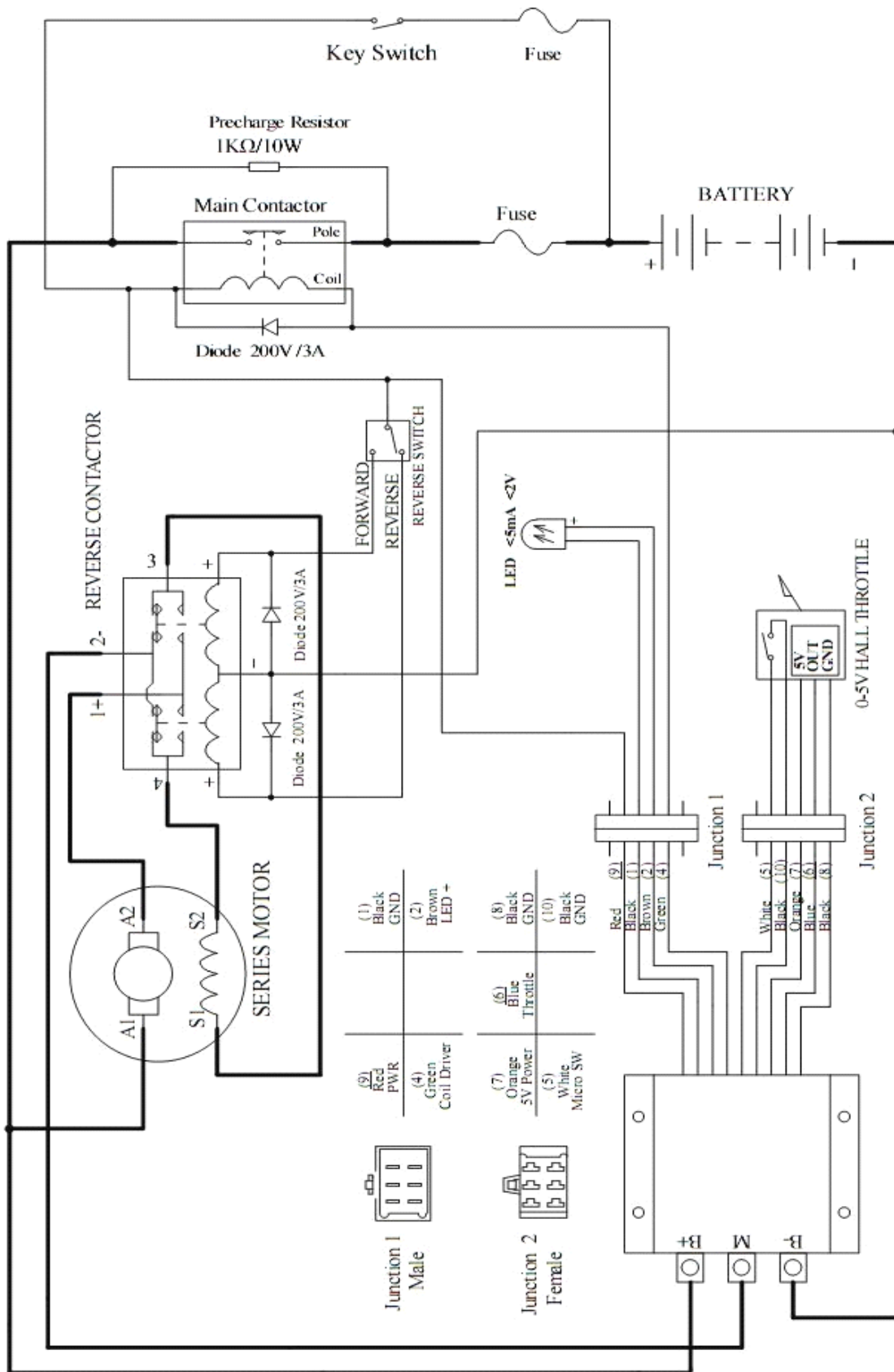
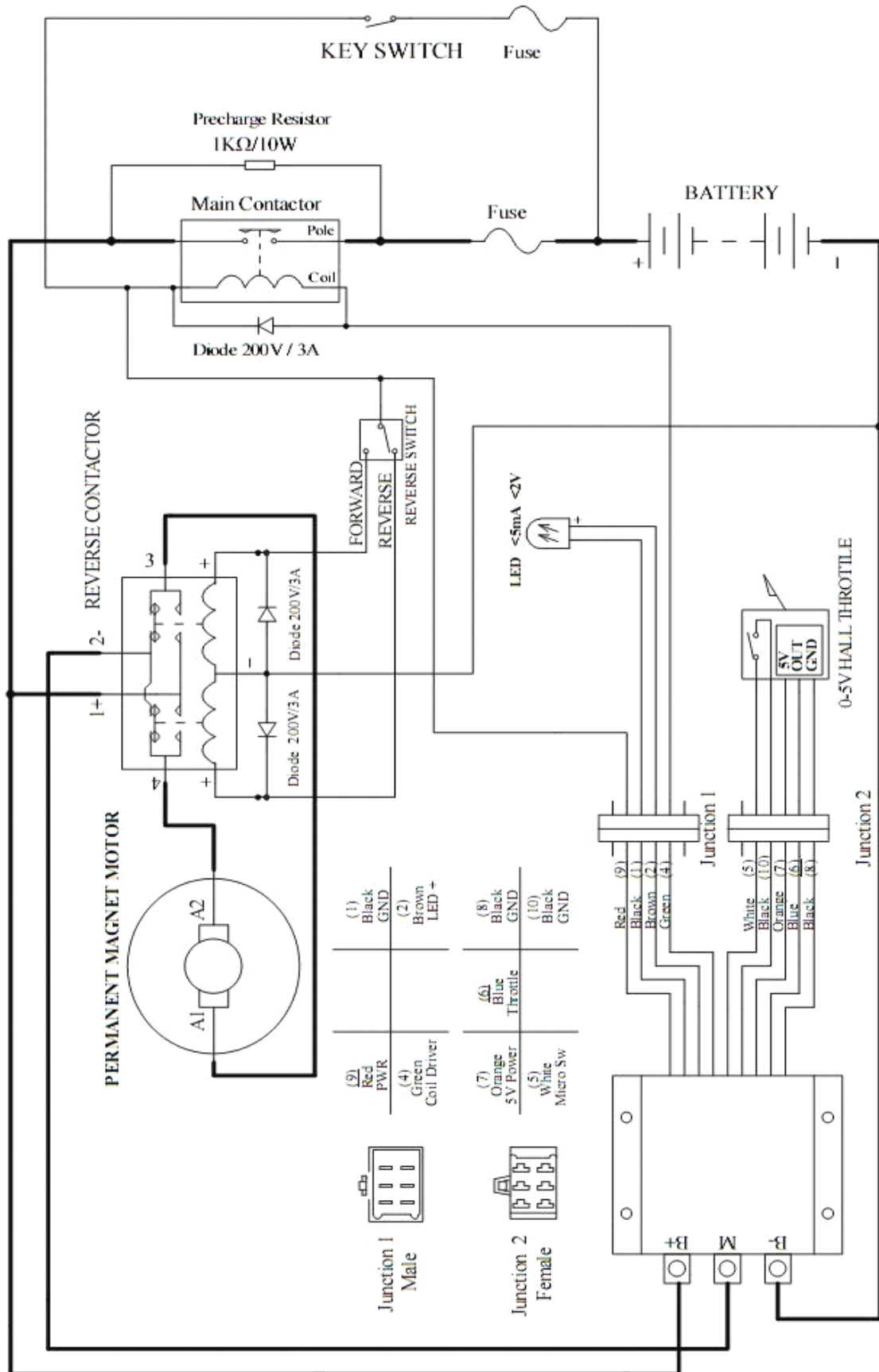

Figure 6: Series motor controller standard wiring



NOTE: Potentiometer can be used to output 0-5V. Please securely wire B- before any other wiring. Never put contactor or break on B-.

Figure 7: PM motor controller standard wiring

3.3 Installation Checkout

Before operating the motor, complete the following checkout procedures. Use LED code as a reference as listed in Table 1.

Caution:

- **Put the vehicle up on blocks to get the drive wheels off the ground before beginning these tests.**
- **Do not allow anyone to stand directly in front of or behind the vehicle during the checkout.**
- **Make sure the PWR switch and the brake is off**
- **Use well-insulated tools.**

- Make sure the wire is connected correctly.
- Turn the PWR switch on. The LED should blink, then stay on steadily when the controller operates normally. If this does not happen, check continuity of the PWR switch circuit and B-connection.
- The fault code will be detected automatically at restart.
- Close the switch and operate the throttle. The motor should spin. If it does not operate, check the voltage at controller terminals. The motor should run faster with increasing throttle. If not, refer to Table 1 LED code, and correct the fault as determined by the fault code.

Chapter 4 Maintenance

There are no user-serviceable parts inside the controllers. Do not attempt to open the controller as this will void your warranty. However, periodic, exterior cleaning of the controller should be carried out.

The controller is a high powered device. When working with any battery powered vehicle, proper safety precautions should be taken that include, but are not limited to, proper training, wearing eye protection, avoidance of loose clothing, hair and jewelry. Always use insulated tools.

4.1 Cleaning

Although the controller requires actually no maintenance after properly installed, the following minor maintenance is recommended in certain applications.

- Remove power by disconnecting the battery, starting with battery positive.
- Discharge the capacitors in the controller by connecting a load (such as a contactor coil or a horn) across the controller's B+ and B- terminals.
- Remove any dirt or corrosion from the bus bar area. The controller should be wiped down with a moist rag. Make sure that the controller is dry before reconnecting the battery.
- Make sure the connections to the bus bars, if fitted, are tight. To avoid physically stressing the bus bars use two, well-insulated wrenches.

Table 1: LED CODES

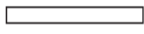
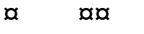
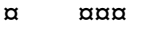
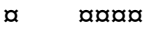
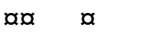
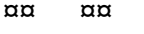
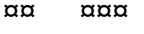
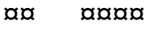
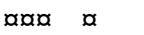
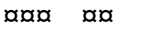
LED Code	Explanation	Solution
Off 	No power or switched off	<ol style="list-style-type: none"> 1. Check if all wires are correct. 2. Check fuse and power supply switch.
On 	Normal operating	That's great! You got solution!
1,2 	Over voltage error	<ol style="list-style-type: none"> 1. Battery voltage is too high for the controller. Check battery volts and configuration. 2. The controller will clear after 5 seconds if battery volts returns to normal.
1,3 	Low voltage error	<ol style="list-style-type: none"> 1. The controller will clear after 5 seconds if battery volts returns to normal. 2. Check battery volts & recharge if required.
1,4 	Temperature warning error	<ol style="list-style-type: none"> 1. Controller case temperature is above 90°C. 2. Current will be limited. Release or reduce throttle until controller cools down.
2,1 	Throttle sensor fault	<ol style="list-style-type: none"> 1. Check if all wires are correct. 2. Check if the throttle type is correct. 3. Check if the voltage is above 5V when use 0-5V hall throttle. 4. Check if connects to the right panel, conforming to configured throttle type.
2,2 	Internal volts fault	<ol style="list-style-type: none"> 1. Measure that B+ & PWR are correct 2. There may be excessive load on the +5V supply. 3. Controller is damaged. Contact Kelly about a warranty repair.
2,3 	Over temperature	The controller temperature has exceeded 100°C. The controller will be stopped but will restart when temperature falls below 80°C.
2,4 	Throttle error at power-up	Throttle signal is higher than the preset 'dead zone' at Power On. Fault clears when throttle is released.
3,1 	Frequent reset	Fault clears after the restart.
3,2 	Internal reset	May be caused by some transient fault condition like a temporary over-current, momentarily high or low battery voltage. This can happen during normal operation.

The LED flashes once at power on as a confidence check and then stays on for normal operation. "1, 2" means it flashed once and after 0.5 second pause, flashes twice. The time between two flashes is 0.25 second. The pause time between multiple flash code groups is 1 second.

Contact Us:

Kelly Controls, LLC

Home Page:

<http://www.kellycontroller.com>

E-mail:

support@kellycontroller.com

Phone:

(01) 224 637 5092