

# **Kelly KHB/HP High Power Brushless Motor Controller User's Manual**

## **Devices Supported:**

<b>KHB72701</b>	<b>KHB14201</b>
<b>KHB72101</b>	<b>KHB14301</b>
<b>KHB12151</b>	<b>KHB14401</b>
<b>KHB12201</b>	<b>KHB14601</b>
<b>KHB12251</b>	<b>KHB14801</b>
<b>KHB12301</b>	
<b>KHB12401</b>	
<b>KHB12601</b>	
<b>KHB12801</b>	
<b>HP12101</b>	

# Contents

Chapter 1	Introduction	2
1.1	Overview	2
Chapter 2	Features and Specifications	3
2.1	General functions	3
2.2	Features	4
2.3	Specifications	5
2.4	Naming Regulations	5
Chapter 3	Wiring and Installation	6
3.1	Mounting the Controller	6
3.2	Connections	11
3.2.1	Front Panel and back panel of KHB Motor Controller:	11
3.2.2	Front Panel and back panel of HP Motor Controller:	12
3.2.3	Wiring of KHB/HP Motor Controller	14
3.2.4	Communication Port	16
3.3	Mounting the Capacitor for HP Motor Controller:	16
3.4	Connections	17
3.4.1	Front Panel and back panel of Capacitor:	17
3.5	Installation Check List	18
Chapter 4	Maintenance	19
4.1	Cleaning	19
4.2	Configuration	19
Table 1:	LED CODES	20
Table 2:	KHB/HP Controller CAN Commands List	22
Contact Us:		26

# Chapter 1 Introduction

## 1.1 Overview

This manual introduces the Kelly high power BLDC motor controllers' features, their installation and their maintenance. Read the manual carefully and thoroughly before using the controller. If you have any questions, please contact the support center of Kelly Controls, LLC.

Kelly's programmable motor controllers provide high efficient, smooth and quiet controls for electric motorcycles, forklifts, hybrid vehicles, electric vehicles and electric boats, as well as industrial motor speed or torque control. It uses high power MOSFET's and, PWM to achieve efficiencies of up to 99% in most cases. A powerful microprocessor brings in comprehensive and precise control to the controllers. It also allows users to adjust parameters, conduct tests, and obtain diagnostic information quickly and easily.

## Chapter 2 Features and Specifications

### 2.1 General functions

- (1) Extended fault detection and protection. The LED flashing pattern indicates the fault sources. Green LED indicates normal operation. Controller will shut down in some fault conditions.
- (2) Monitoring battery voltage. It will stop driving if the battery voltage is too high and it will progressively cut back motor drive power as battery voltage drops until it cuts out altogether at the preset "Low Battery Voltage" setting.
- (3) Built-in current loop and over current protection.
- (4) Configurable motor temperature protection range.
- (5) Current cutback at low temperature and high temperature to protect battery and controller. The current begins to ramp down at 90°C case temperature, shutting down at 100°C.
- (6) Enhanced regen brake function. A novel ABS technique provides powerful and smooth regen.
- (7) The controller keeps monitoring battery recharging voltage during regenerative braking, progressively cutting back current as battery voltage rises then cutting off regen altogether when voltage goes too high.
- (8) Pulsed reverse alarm output.
- (9) 3 switch inputs which are activated by connection to Ground. Default to throttle switch, brake switch and reversing switch.
- (10) 3 analog 0-5V inputs that default to throttle input, brake input and motor temperature input.
- (11) Provision of a +5 volt output to supply various kinds of sensors, including Hall effect type.
- (12) Main contactor driver. Cutting off the power if any fault is detected.
- (13) Current meter to display both drive and regen current. Save shunt.
- (14) 3 hall position sensor inputs. Open collector, pull up provided.
- (15) Maximum reverse speed is configurable to half of max forward speed.
- (16) Configurable and programmable with a host computer though RS232 or USB. Provide free GUI which can run on Windows XP/2000, Windows 7 and Vista(recommend using Kelly Standard USB To RS232 Converter).
- (17) Configurable boost switch. Enables the maximum output power achievable if the switch is turned on.
- (18) Configurable economy switch. Limits the maximum current to half if the switch is turned on.
- (19) Maximum reverse power is configurable to half power.
- (20) Configurable 12V brake signal input, in lieu of motor temperature sensor.
- (21) Optional joystick throttle. A bi-symmetrical 0-5V signal for both forwarding and reversing
- (22) Configurable motor over-temperature detection and protection with the recommended thermistor KTY83-122.
- (23) Optional CAN bus.
- (24) Supply voltage 8V-30V.

***Caution!*** *Regeneration has braking effect but does not replace the function of a mechanical brake. A mechanical brake is required to stop your vehicle. Regen IS NOT a safety feature!*

*Controller may stop regen, without warning, to protect itself or the battery(it won't protect you!).*

## 2.2 Features

- 1) Opto-isolated technology achieve stability.
- 2) Intelligence with powerful microprocessor.
- 3) Synchronous rectification, ultra low drop and fast PWM to achieve very high efficiency.
- 4) Electronic reversing.
- 5) Voltage monitoring on 3 motor phases, bus, and power supply.
- 6) Voltage monitoring on voltage source 12V and 5V.
- 7) Current sense on all 3 motor phases.
- 8) Current control loop.
- 9) Hardware over current protection.
- 10) Hardware over voltage protection.
- 11) Support torque mode, speed mode, and balanced mode operation.
- 12) Configurable limit for motor current and battery current.
- 13) Low EMC.
- 14) LED fault code.
- 15) Battery protection: current cutback, warning and shutdown at configurable high and low battery voltage.
- 16) Rugged aluminum housing for maximum heat dissipation and harsh environment. Support fan or water cooling.
- 17) Rugged high current terminals, and rugged aviation connectors for small signal.
- 18) Thermal protection: current cut back, warning and shutdown at high temperature.
- 19) Configurable 60 degree or 120 degree hall position sensors.
- 20) Support motors with any number of poles. Up to 40,000 electric RPM standard. Optional high speed 70,000 ERPM, and ultra high speed 100,000 ERPM.  
(Electric RPM = mechanical RPM \* motor pole pairs).
- 21) Support three modes of regenerative braking: brake switch regen, release throttle regen, 0-5K or 0-5V analog signal variable regen.
- 22) Configurable high pedal protection: Disable operation if power up with high throttle.
- 23) Current multiplication: Take less current from battery, output more current to motor.
- 24) Easy installation: 2 or 3-wire pot, or hall sensor throttle can work with KHB and HIP controllers.
- 25) Remote fault code LED driver.
- 26) Current meter output.
- 27) Standard PC/Laptop computer is used to do programming. No special tools needed.
- 28) User program provided. Easy to use. No cost to customers.

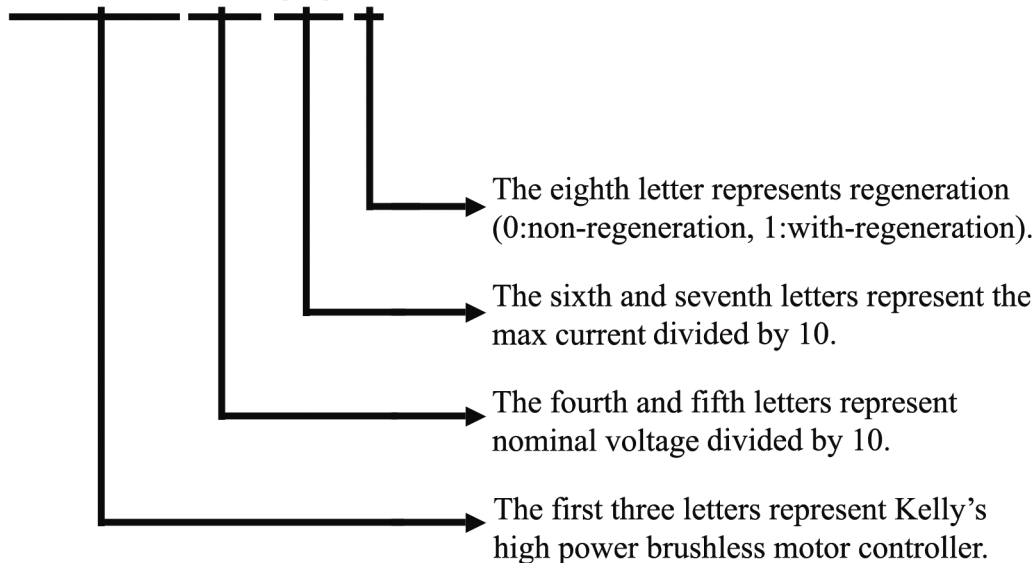
## 2.3 Specifications

- Frequency of Operation: 16.6kHz.
- Standby Battery Current depending on the model: usually less than 2mA.
- 5V Sensor Supply Current: 40mA.
- Controller supply voltage range, PWR, 8 to 30V (24V preferred)
- Controller input power, PWR: less than 10W.
- Configurable battery voltage range, B+. Max operating range: 18V to 136V for controller rated equal 120V. 18V to 180V for controller rated equal 144V.
- Standard Throttle Input: 0-5 Volts(3-wire resistive pot), 1-4 Volts(hall active throttle).
- Analog Brake and Throttle Input: 0-5 Volts. Producing 0-5V signal with 3-wire pot.
- Reverse Alarm, Main Contactor Coil Driver, Meter.
- Full Power Operating Temperature Range: 0 °C to 50 °C (controller case temperature).
- Operating Temperature Range: -30 °C to 90 °C, 100 °C shutdown(controller case temperature).
- Motor Current Limit, 1 minute: 150A - 1000A, depending on the model.
- Motor Current Limit, continuous: 75A - 500A, depending on the model.
- Max Battery Current : Configurable.

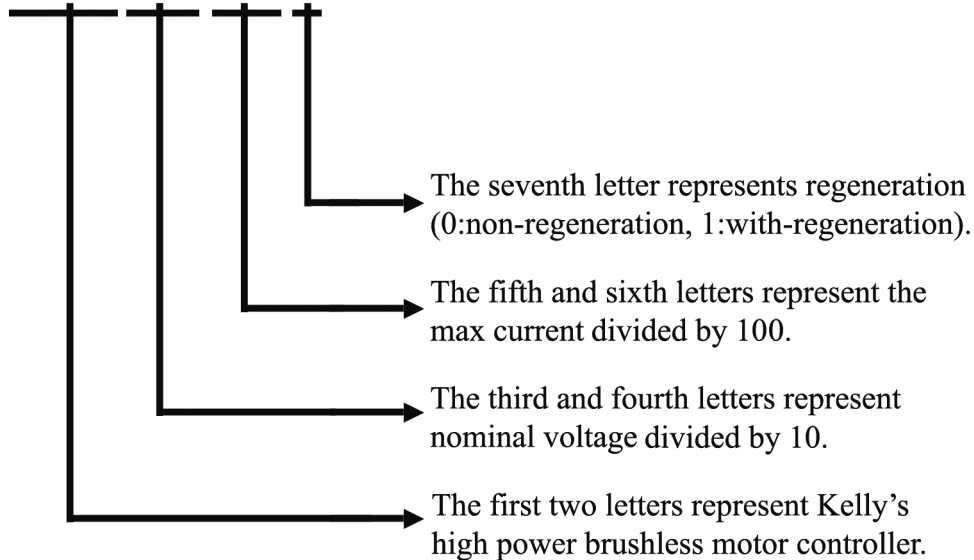
## 2.4 Naming Regulations

The naming regulations of Kelly KHB/HP BLDC motor controllers:

**KHB12601**



# HP12 101



## Chapter 3 Wiring and Installation

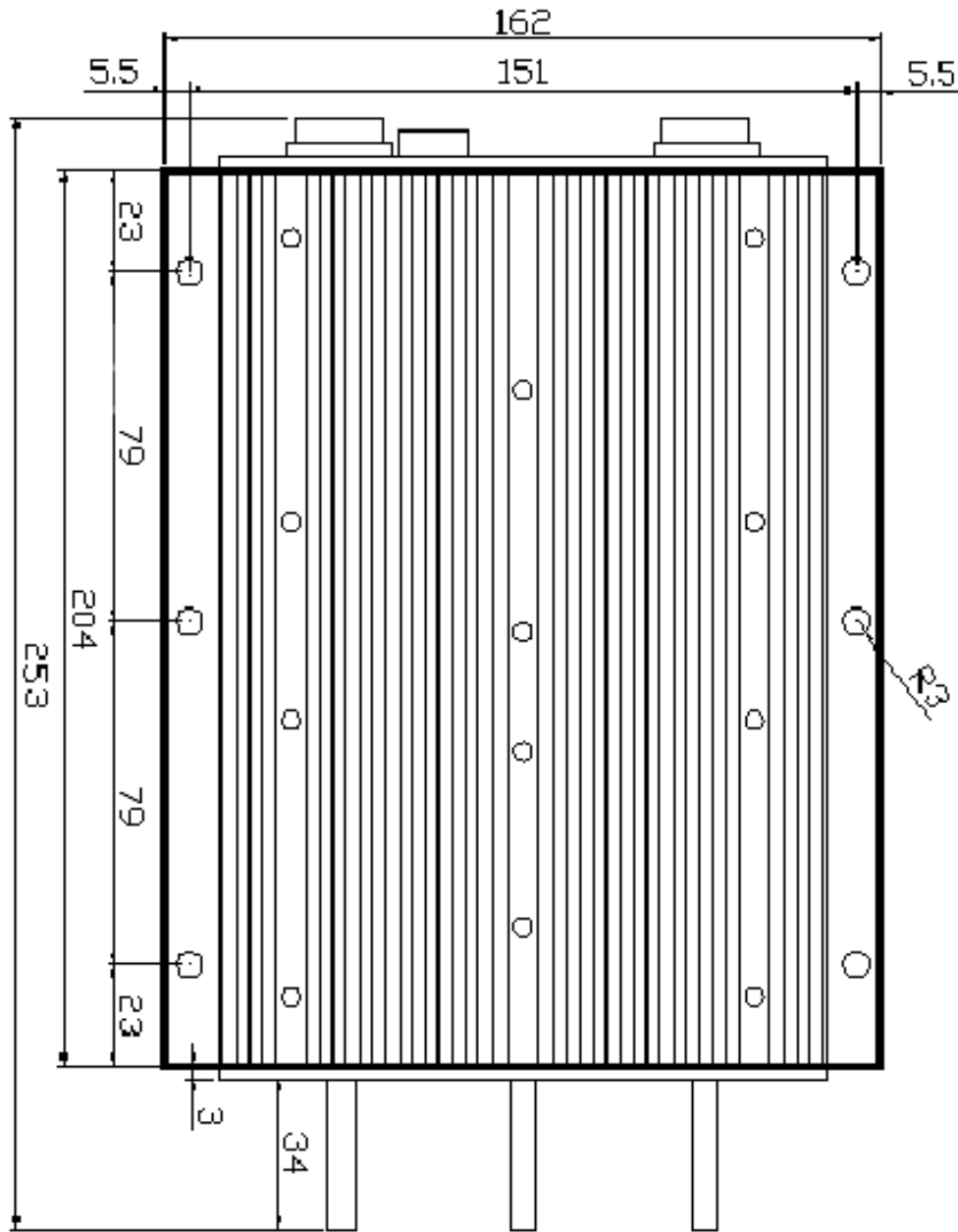
### 3.1 Mounting the Controller

The controller can be oriented in any position which should be as clean and dry as possible, and if necessary, shielded with a cover to protect it from water and contaminants.

To ensure full rated output power, the controller should be fastened to a clean, flat metal surface with six screws. Applying silicon grease or some other thermal conductive material to contact surface will enhance thermal performance.

Proper heat sinking and airflow are vital to achieve the full power capability of the controller.

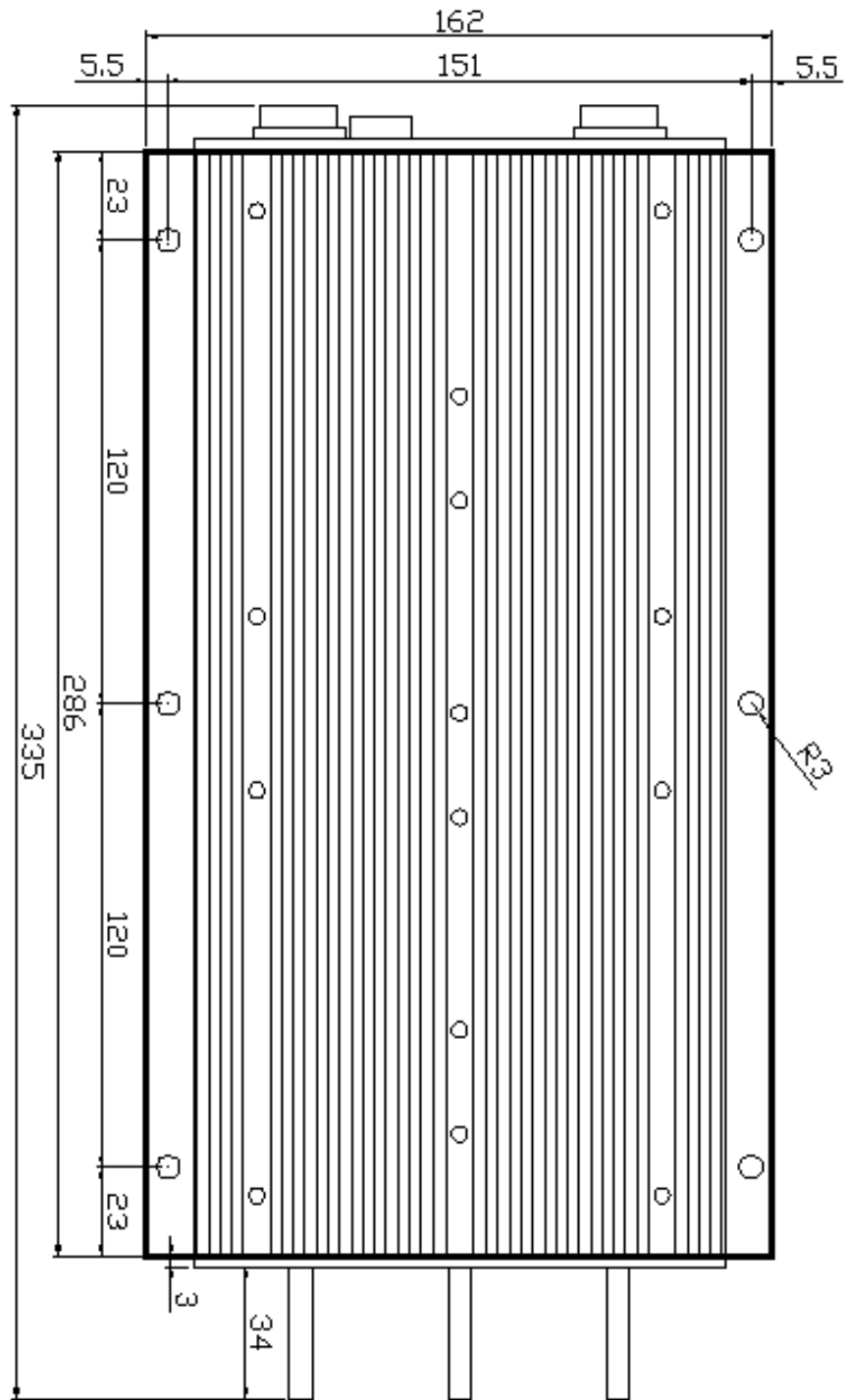
**The case outline and mounting holes' dimensions of KHB Controllers:**



Height: 84 millimeters  
 Length: 204 millimeters

**Figure 1:** KHB mounting holes' dimensions (dimensions in millimeters)

Controller models with above dimension: KHB12151, KHB12201, KHB12251  
 KHB12301, KHB12401  
 KHB14201



Height: 84 millimeters

Length: 286 millimeters

**Figure 2:** KHB mounting holes' dimensions (dimensions in millimeters)

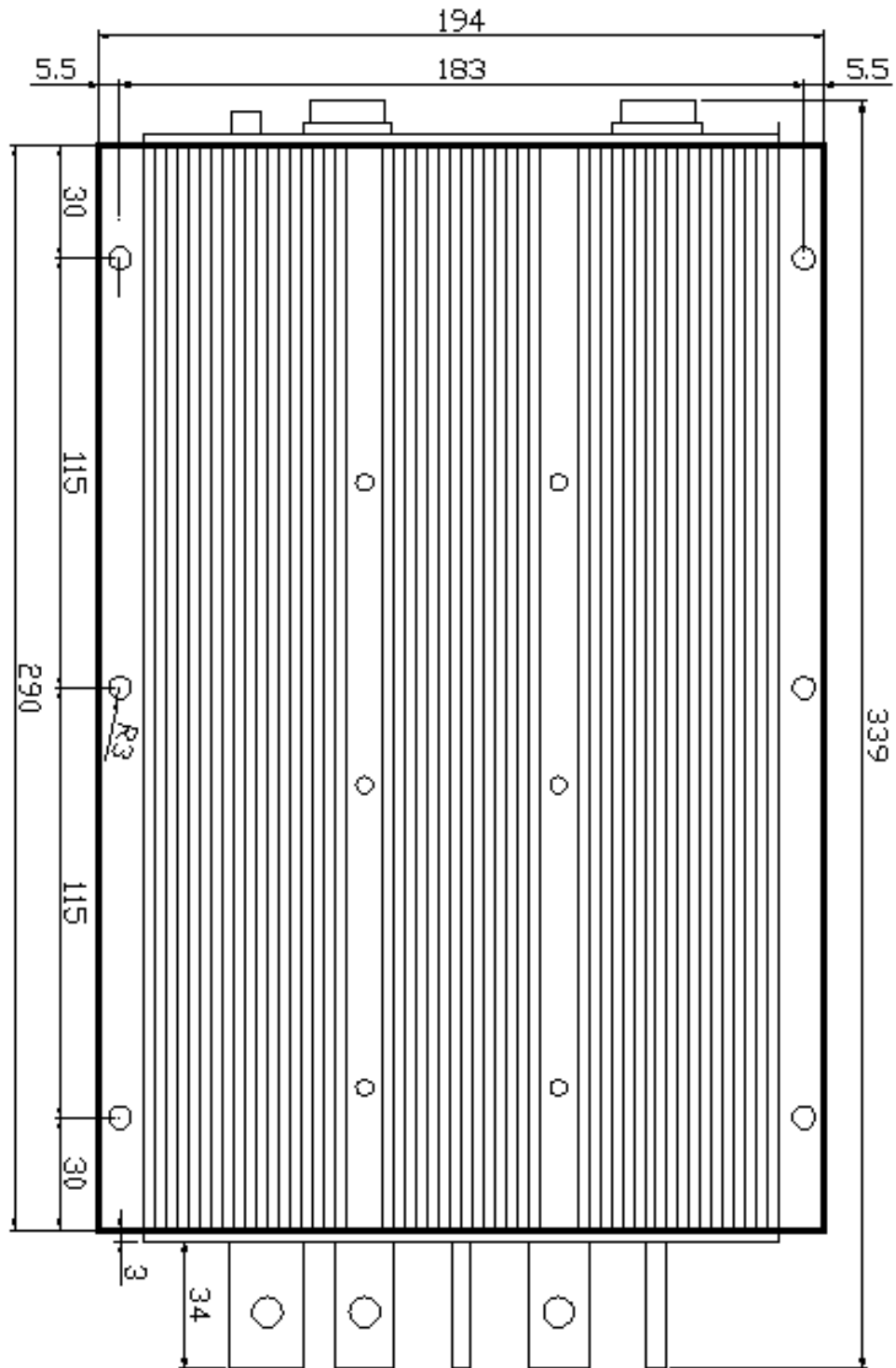
Controller models with above dimension: KHB72701, KHB72101

KHB12601, KHB12801

KHB14301, KHB14401, KHB14601



**The case outline and mounting holes' dimensions of HP Controllers:**



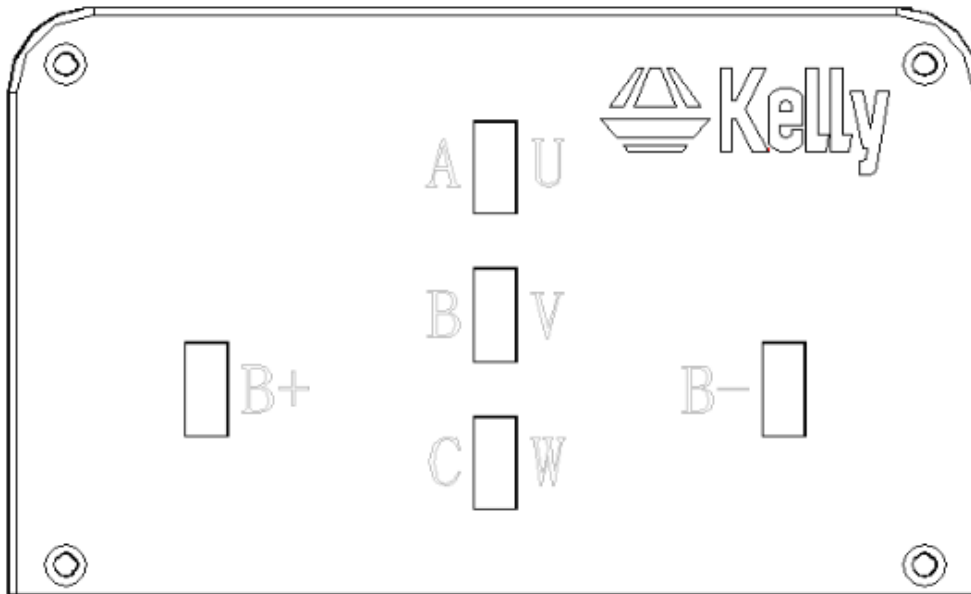
Height: 78.5 millimeters

**Figure 4:** HP mounting holes' dimensions (dimensions in millimeters)

### 3.2 Connections

#### 3.2.1 Front Panel and back panel of KHB Motor Controller:

Five metal bars in front panel and two plugs (J1, J2) in back panel are provided for connecting to the battery, motor and control signals shown as Figure 5, 6 and 9.



**Figure 5:** Front panel of KHB motor controller

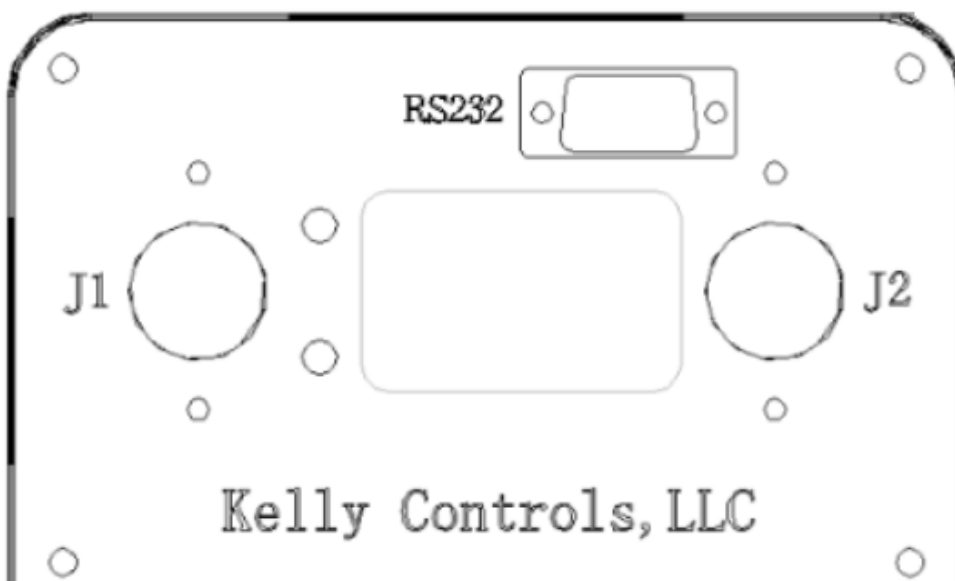
**B+:** battery positive

**B-:** battery negative

**A/U:** Output A/U phase

**B/V:** Output B/V phase

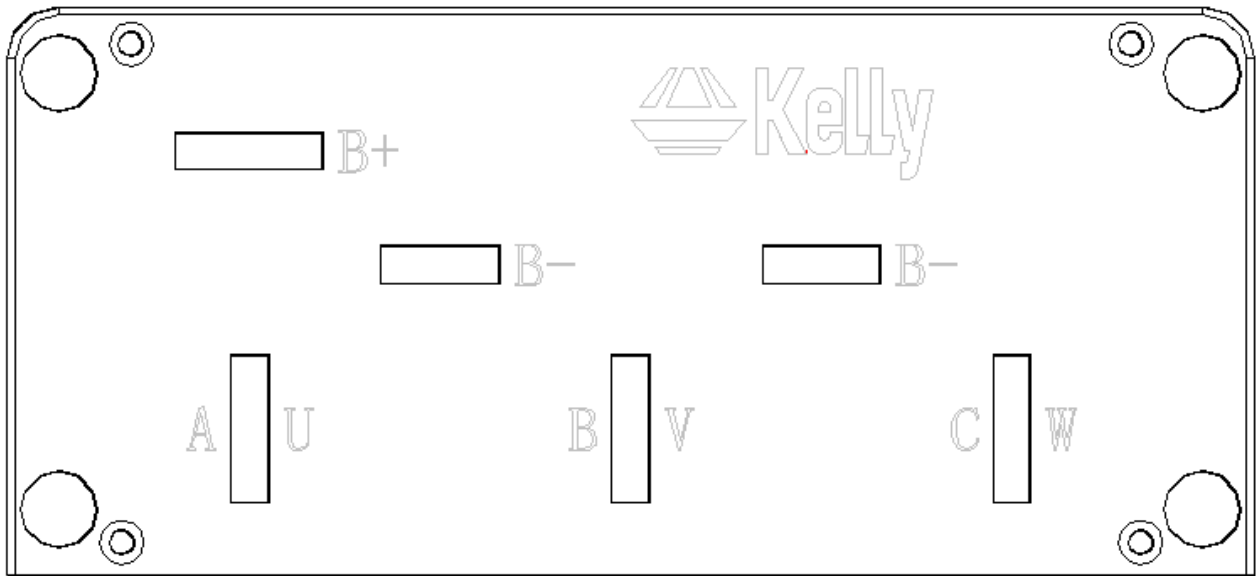
**C/W:** Output C/W phase



**Figure 6:** Back panel of KHB motor controller

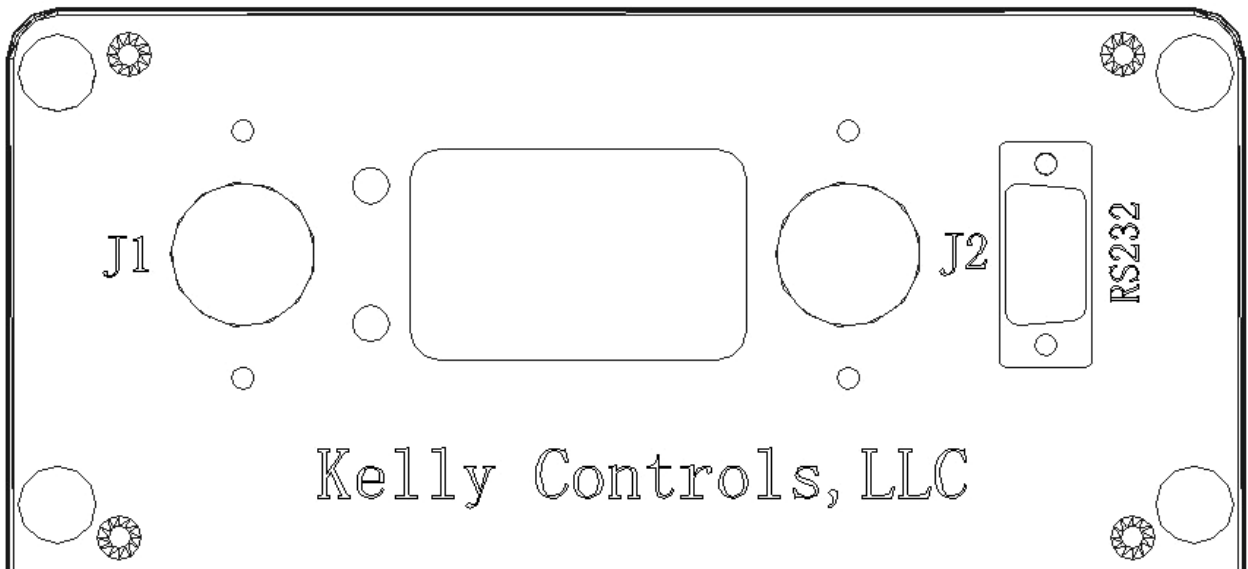
**3.2.2 Front Panel and back panel of HP Motor Controller:**

Seven metal bars in front panel and two plugs (J1, J2) in back panel are provided for connecting to the battery, motor and control signals shown as Figure 7, 8 and 9.

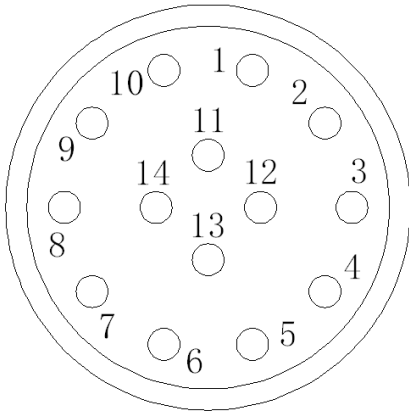


**Figure 7:** Front panel of HP motor controller

- B+:** battery positive
- B-:** battery negative
- A/U:** Output A/U phase
- B/V:** Output B/V phase
- C/W:** Output C/W phase



**Figure 8:** Back panel of HP motor controller



**Figure 9:** The connecting diagram of **J1** and **J2**

### J1 Pin Definition

- 1- **PWR: Controller power supply (output).**
- 2- **Current meter. <200mA**
- 3- **Main contactor driver. <2A**
- 4- **Alarm: To drive reverse beeper. <200mA**
- 5- **RTN: Signal return**
- 6- **Green LED: Running indication**

- 7- **RTN: Signal return**
- 8- **Reserved**
- 9- **Boost Switch (only available on the controller with 32-bit micro)**
- 10- **CAN bus high**
- 11- **CAN bus low**
- 12- **12V brake**
- 13- **RTN: Signal return, or power supply return**
- 14- **Red LED: Fault code.**

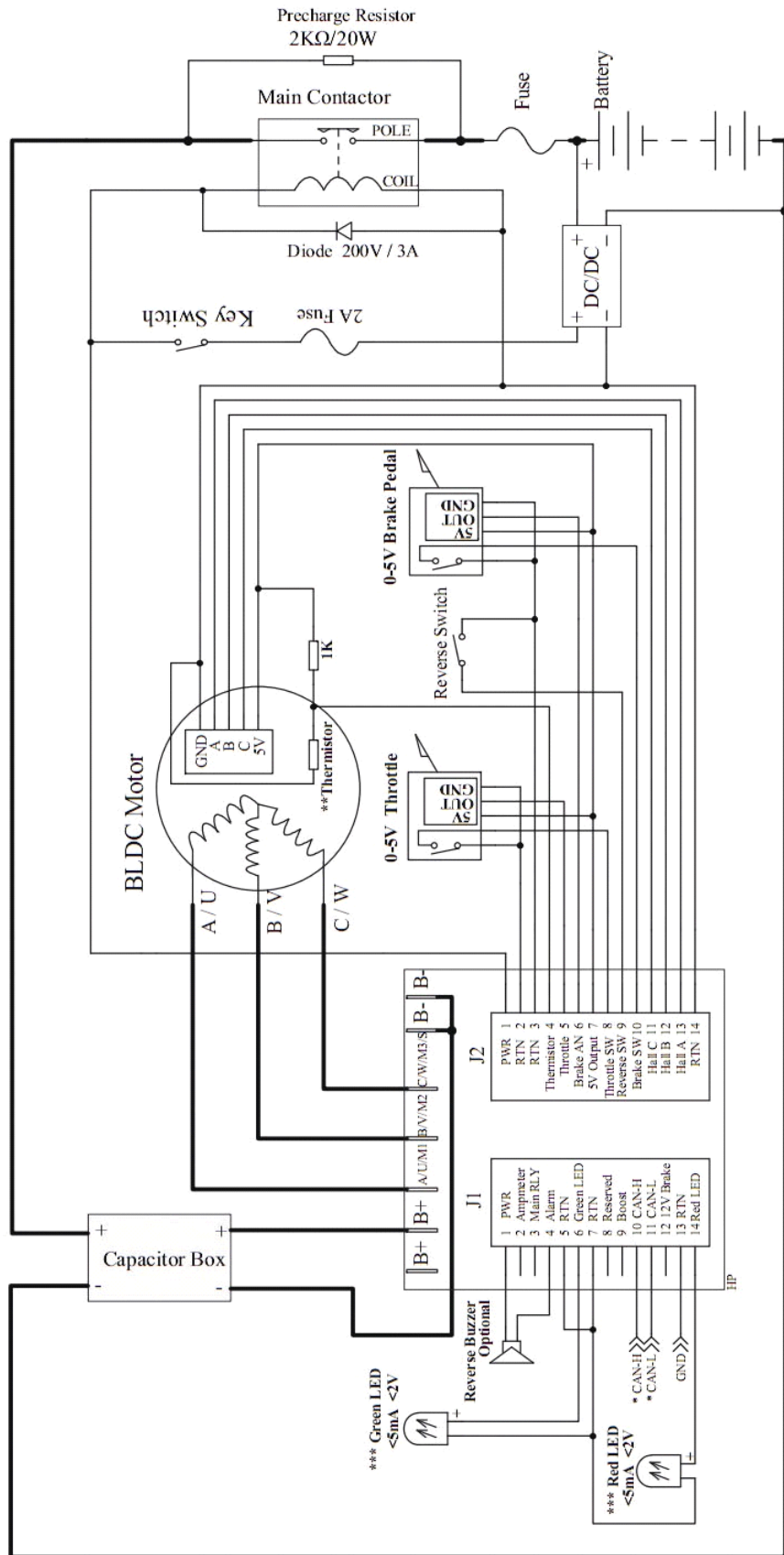
### J2 Pin Definition

- 1- **PWR: Controller power supply (input)**
- 2- **RTN: Signal return, or power supply return**
- 3- **RTN: Signal return**
- 4- **Motor temperature input.**
- 5- **Throttle analog input, 0-5V**
- 6- **Brake analog input, 0-5V**
- 7- **5V: 5V supply output. <50mA**
- 8- **Micro\_SW: Throttle switch input**
- 9- **Reversing switch input**
- 10- **Brake switch input**
- 11- **Hall phase C**
- 12- **Hall phase B**
- 13- **Hall phase A**
- 14- **RTN: Signal return**

#### Notes:

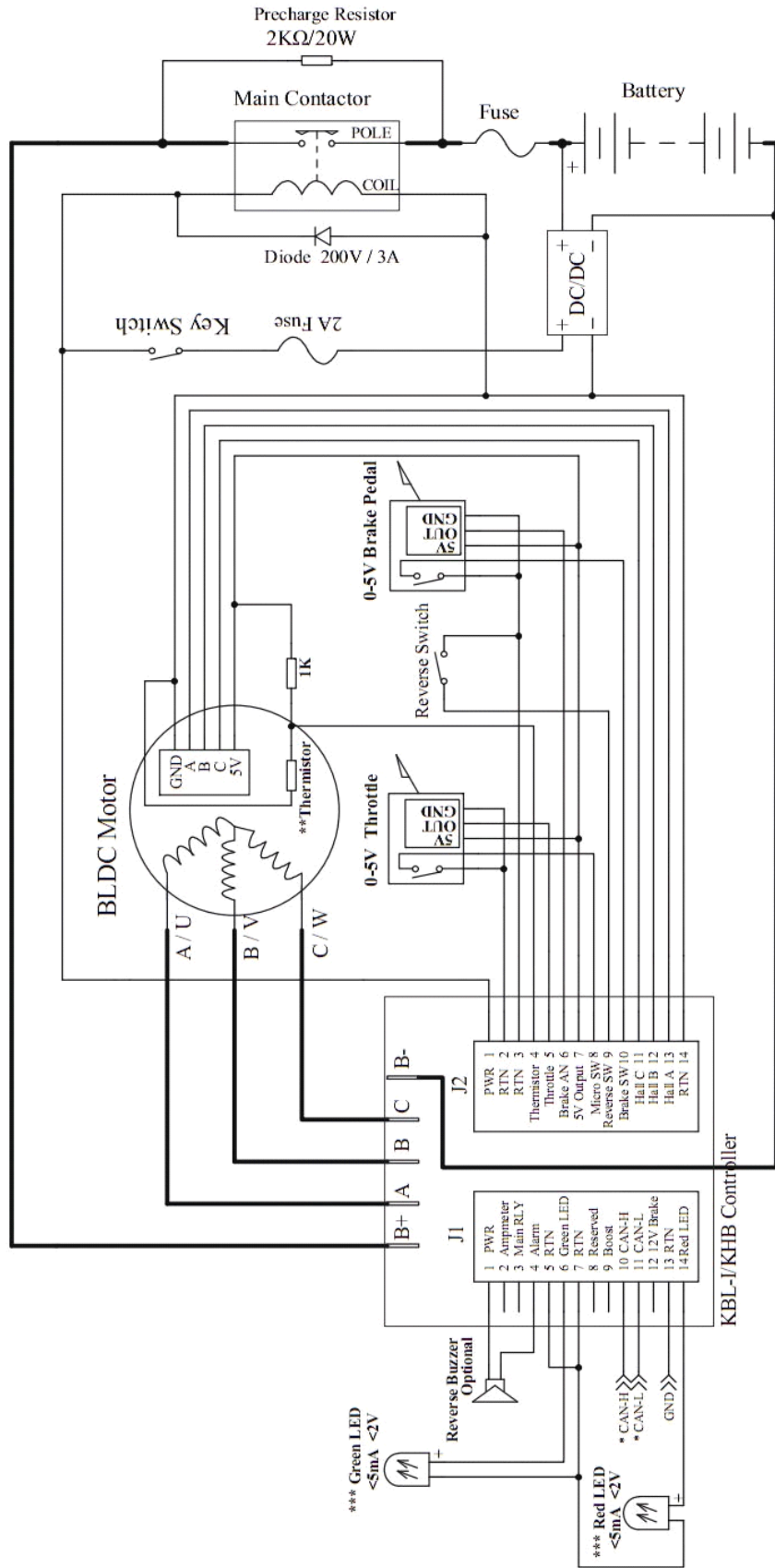
1. **All RTN and GND pins are internally connected, but isolated from B-.**
2. **Two PWR pins, J1-1 and J2-1, are internally connected. It's recommended to use J1-1 to supply peripherals like alarm and contactor. Twist peripheral wires with PWR is the preferred for EMC.**
3. **Kelly Ammeter positive connect to 5V power supply of controller, negative to J1-2.**
4. **Switch to ground is active. Open switch is inactive.**

### 3.2.3 Wiring of KHB/HP Motor Controller



NOTE: 0-5K potentiometer can be used as throttle signal. Wire 5V and RTN to two end terminals, and wiper will output 0-5V signal.  
 Please securely wire B- before any other wiring. Never put contactor or break on B-.  
 \* CAN bus is deprecated by default.  
 \*\* Thermistor is optional item. default to KTY83-122.  
 \*\*\* When you connect an external LED, the LED front panel brightness will be reduced.

Figure 10: Standard Wiring for HP Controllers

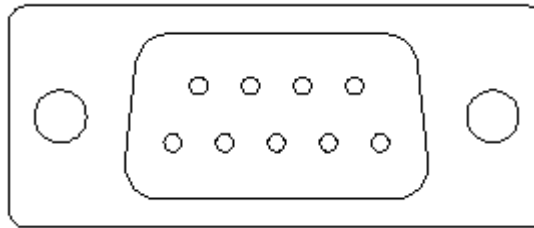


NOTE: 0-5K potentiometer can be used as throttle signal. Wire 5V and RTN to two end terminals, and wiper will output 0-5V signal. Please securely wire B- before any other wiring. Never put contactor or break on B-.  
 \* CAN bus is deprecated by default.  
 \*\* Thermistor is optional item. default to KTY83-122.  
 \*\*\* When you connect an external LED, the LED front panel brightness will be reduced.

**Figure 11:** Standard Wiring for KHB Controllers (12V or 24V battery supply is required)

### 3.2.4 Communication Port

A RS232 port is provided to communicate with host computer for calibration and configuration.

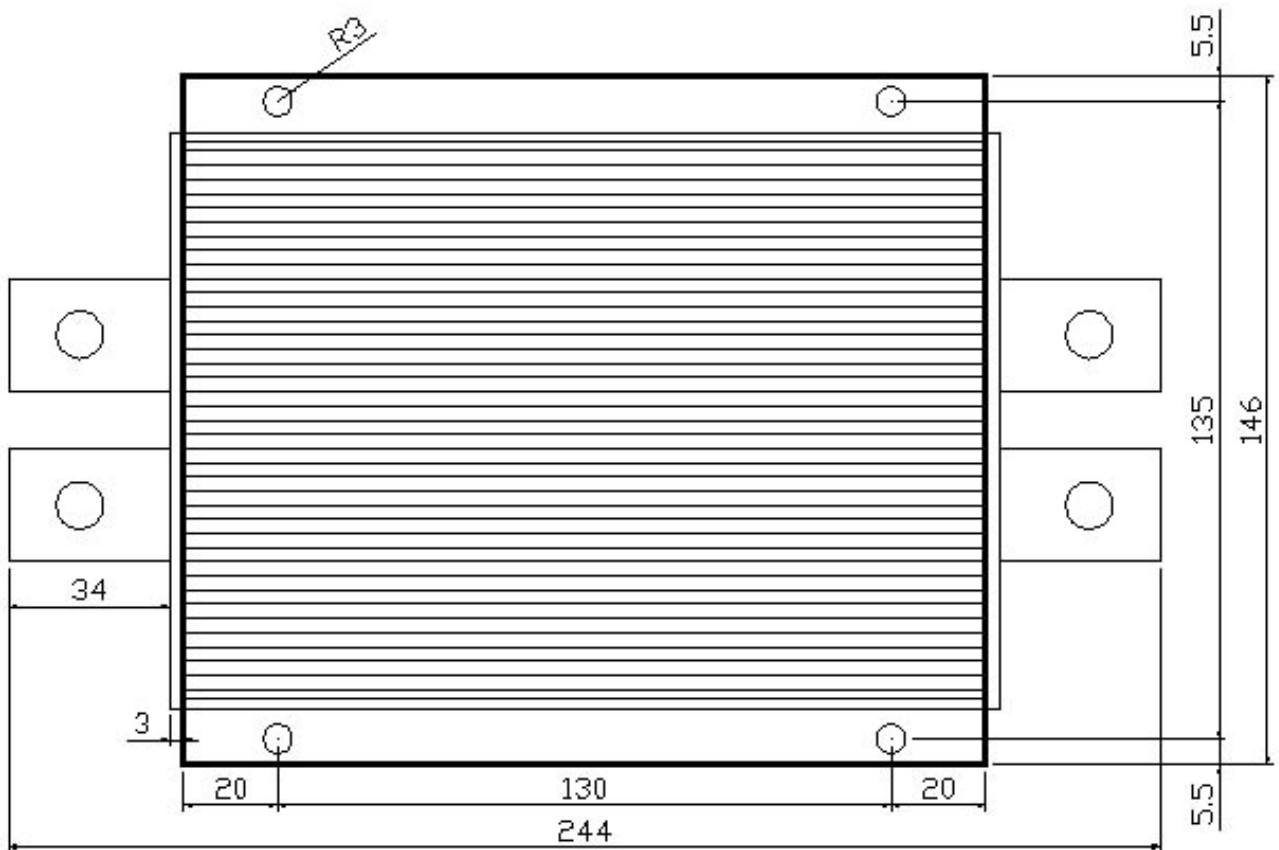


**Figure 12:** standard RS232 Interface

### 3.3 Mounting the Capacitor for HP Motor Controller:

The capacitor can be oriented in any position which should be as clean and dry as possible, if necessary, shielded with a cover to protect it from water and contaminants.

The outline and mounting holes dimensions of the capacitor are shown in Figure 13.



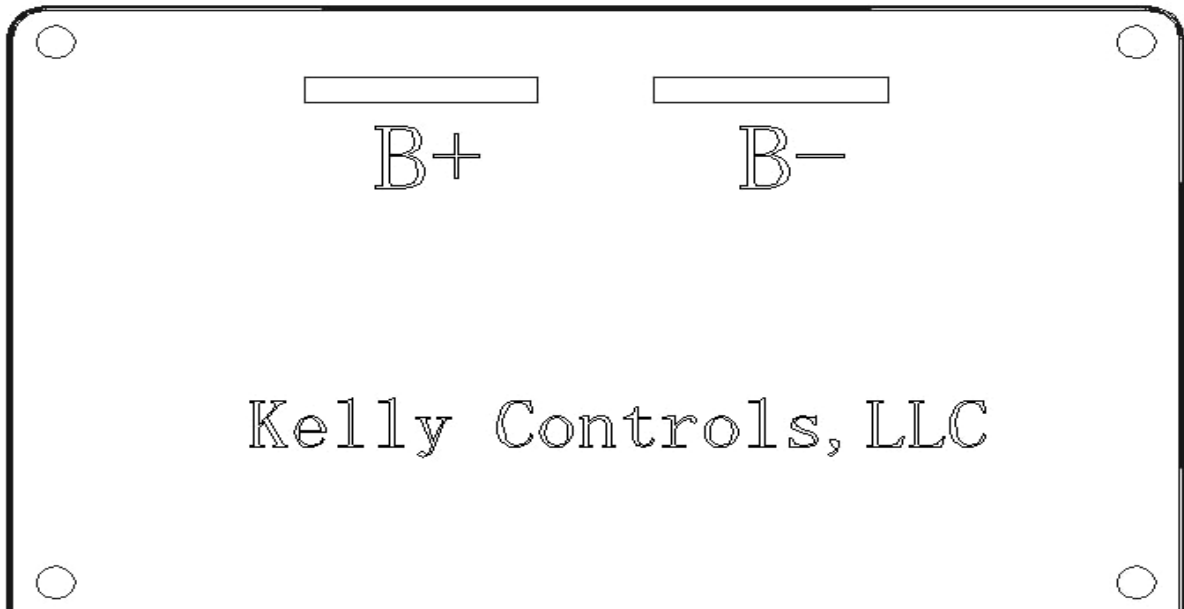
Height: 75 millimeters

**Figure 13:** Capacitor mounting holes dimensions (dimensions in millimeters)

## 3.4 Connections

### 3.4.1 Front Panel and back panel of Capacitor:

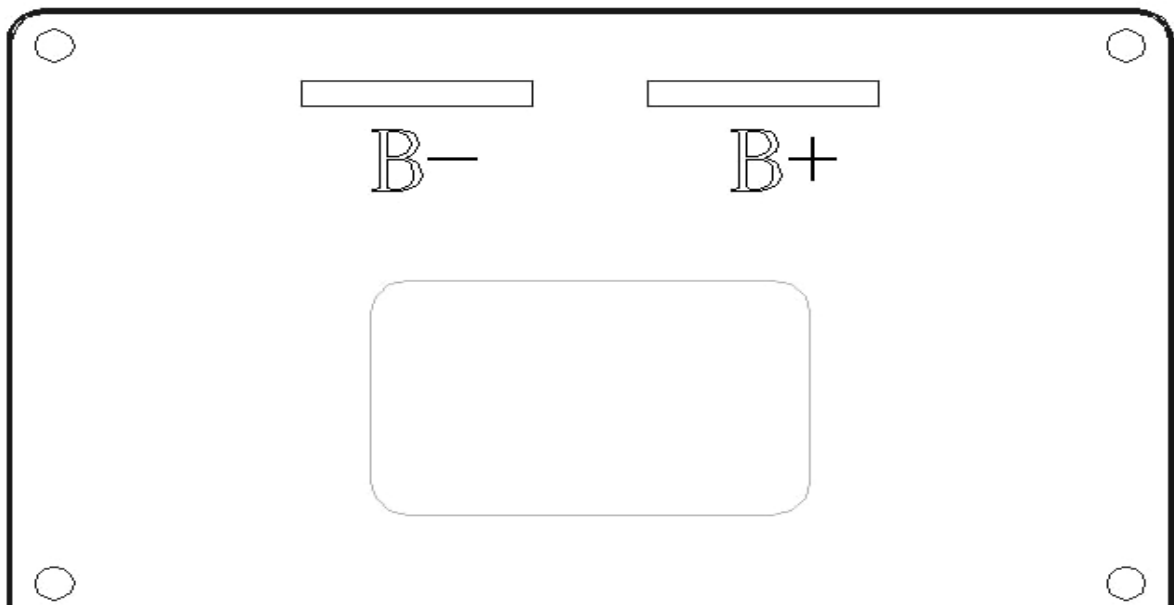
Two metal bars in front panel and two in back panel are provided for connecting to the battery and HP BLDC controller shown as Figure 14 and Figure 15.



**Figure 14:** Front Panel of Capacitor

**B+:** battery positive

**B-:** battery negative



**Figure 15:** Back Panel of Capacitor

**B+:** battery positive

**B-:** battery negative

**Caution:**

- **Do not apply power until you are certain the controller wiring is correct and has been double checked. Wiring faults will damage the controller.**
- **Ensure that the B- wiring is securely and properly connected before applying power.**
- **The preferred connection of the system contactor or circuit breaker is in series with the B+ line.**
- **All contactors or circuit breakers in the B+ line must have precharge resistors across their contacts. Lack of even one of these precharge resistors may severely damage the controller at switch-on.**

### 3.5 Installation Check List

Before operating the vehicle, complete the following checkout procedures. Use LED code as a reference as listed in Table 1.

**Caution:**

- **Put the vehicle up on blocks to get the drive wheels off the ground before beginning these tests.**
- **Do not allow anyone to stand directly in front of or behind the vehicle during the checkout.**
- **Make sure the PWR switch and the brake is off**
- **Use well-insulated tools.**

- Make sure the wire is connected correctly
- Turn on the PWR switch, the Red flashes once and the Green is off. After the start-up delay, normally the Red will stay off and the Green will turn on. If there is error, the Red LED will flashes for fault codes.  
If the S/N less: 11xxxxxx: Turn on the PWR switch, the Red flashes once and the Green is on. Normally, the Red will stay off. If there is error, the Red LED will flashes for fault codes.
- The fault code will be detected automatically at restart.
- With the brake switch open, select a direction and operate the throttle. The motor should spin in the selected direction. Verify wiring or voltage and the fuse if it does not. The motor should run faster with increasing throttle. If not, refer to the Table 1 LED code, and correct the fault as determined by the fault code.
- Take the vehicle off the blocks and drive it in a clear area. It should have smooth acceleration and good power.

## Chapter 4 Maintenance

There are no user-serviceable parts inside the controllers. Do not attempt to open the controller as this will void your warranty. However, periodic, exterior cleaning of the controller should be carried out.

The controller is a high powered device. When working with any battery powered vehicle, proper safety precautions should be taken that include, but are not limited to, proper training, wearing eye protection, avoidance of loose clothing, hair and jewelry. Always use insulated tools.

### 4.1 Cleaning

Although the controller requires virtually no maintenance after properly installation, the following minor maintenance is recommended in certain applications.

- Remove power by disconnecting the battery, starting with battery positive.
- Discharge the capacitors in the controller by connecting a load (such as a contactor coil, resistor or a horn) across the controller's B+ and B- terminals.
- Remove any dirt or corrosion from the bus bar area. The controller should be wiped down with a moist rag. Make sure that the controller is dry before reconnecting the battery.
- Make sure the connections to the bus bars, if fitted, are tight. To avoid physically stressing the bus bars use two, well-insulated wrenches.

### 4.2 Configuration

You can configure the controller with a host computer through either an RS232 or USB port.

- Disconnect motor wiring from controller.
- Do not connect B+, throttle and so on. The controller may display fault code in some conditions, but it doesn't affect programming or configuration.
- Use a straight through RS232 cable or Kelly USB To RS232 Converter to connect to a host computer. Provide 10V-30V (either J2 pin1 or J1 pin1) to PWR. Wire power supply return to any RTN pin, isolated from B-.

Download the free configuration software from:

<http://www.kellycontroller.com/support.php>

**Caution:**

- **Make certain that the motor is disconnected before trying to run the Configuration Software!**
- **Configuration software will be regularly updated and published on the website. Please Update your Configuration Software regularly. You must uninstall the older version before updating.**
- **When setting "Hall Sensor Type" in GUI, do not use "Auto-Check". This has been deleted from the newer configuration software versions.**

## Table 1: LED CODES

### Green LED Codes

LED Code	Explanation	Solution
Green Off	No power or switched off	1. Check if all wires are correct. 2. Check fuse and power supply.
Green On	Normal operation	That's great! You got solution!
Green & Red are both On		1. Software still upgrading. 2. Supply voltage too low or battery too high 3. The controller is damaged. Contact Kelly about a warranty repair.

### Red LED Codes

LED Code	Explanation	Solution
1,2 α    αα	Over voltage error	1. Battery voltage is too high for the controller. Check battery volts and configuration. 2. Regeneration over-voltage. Controller will have cut back or stopped regen. 3. This only accurate to $\pm 2\%$ upon Overvoltage setting.
1,3 α    ααα	Low voltage error	1. The controller will clear after 5 seconds if battery volts returns to normal. 2. Check battery volts & recharge if required.
1,4 α    αααα	Over temperature warning	1. Controller case temperature is above 90°C. Current will be limited. Reduce controller loading or switch Off until controller cools down. 2. Clean or improve heatsink or fan.
2,1 αα    α	Motor did not start	Motor did not reach 25 electrical RPM within 2 seconds of start-up. Hall sensor or phase wiring problem.
2,2 αα    αα	Internal voltage fault	1. Measure that B+ & PWR are correct when measured to B- or RTN. 2. There may be excessive load on the +5V supply caused by too low a value of Regen or throttle potentiometers or incorrect wiring. 3. Controller is damaged. Contact Kelly about a warranty repair.
2,3 αα    ααα	Over temperature	The controller temperature has exceeded 100°C. The controller will be stopped but will restart when temperature falls below 80°C.
2,4 αα    αααα	Throttle error at power-up	1. Throttle signal is higher than the preset 'dead zone' at Power On. Fault clears when throttle is

			released. 2. Set throttle model as "Hall Active" throttle in GUI if you use that throttle model.
3,1	aaaa a	Frequent reset	May be caused by over-voltage, bad motor intermittent earthing problem, bad wiring, etc.
3,2	aaaa aa	Internal reset	May be caused by some transient fault condition like a temporary over-current, momentarily high or low battery voltage. This can happen during normal operation.
3,3	aaaa aaaa	Hall throttle is open or short-circuit	When the throttle is repaired, a restart will clear the fault.
3,4	aaaa aaaaa	Non-zero throttle on direction change	Controller won't allow a direction change unless the throttle or speed is at zero. Fault clears when throttle is released.
4,1	aaaaa a	Regen or Start-up over-voltage	Motor drive is disabled if an over-voltage is detected at start-up or during regen. The voltage threshold detection level is set during configuration.
4, 2	aaaaa aa	Hall sensor error	1. Incorrect or loose wiring or a damaged hall sensor. 2. Also be caused by incorrect hall angle configuration (60 degree or 120 degree).
4, 3	aaaaa aaaa	Motor over-temperature	Motor temperature has exceeded the configured maximum. The controller will shut down until the motor temperature cools down.

The Red LED flashes once at power on as a confidence check and then normally stays Off. "1, 2" means the Red flashes once and after a second pause, flashes twice. The pause time between multiple flash code groups is two seconds.

## Table 2: KHB/HP Controller CAN Commands List

### Version 1.1

#### You should specify when sending:

**ID:**Our default ID is 0x6B, so only the data frame with ID 107 can be received by our controller. However, it can be set by configuration program.

**Frame type:**data frame

**Frame format:**standard 11 bits ID

**Length:**the number of data field bytes

**Data field:**data[0] is the command which indicates the operation.

#### Controller response:

**ID:**The controller sends data frames with ID 115, 0x73. It also can be set by configuration program.

**Frame type:**data frame

**Length:**the number of data field bytes

**Data field:**The controller sends one or two data frames in response.

#### Commands definitions

Command **CCP\_FLASH\_READ**

Length 3

data[0] 0xF2

data[1] INFO\_MODULE\_NAME

data[2] 8

Controller response

Length 8

data[0]~data[7] Controller's model in ASCII format, 8 bytes.

Description: Getting controller's model no. E.g. 0x4B,0x42,0x4C is 'K' , 'B', 'L', 0x30 is '0' . INFO\_MODULE\_NAME constant is defined as 64.

Command **CCP\_FLASH\_READ**

Length 3

data[0] 0xF2

data[1] INFO\_SOFTWARE\_VER

data[2] 2

Controller response

Length 2

data[0]~data[1] software version in BCD alike format, two bytes.

Description: Getting controller's software version, it also define as the controller's version, BCD alike format storage. E.g. 0x0A,0x01 should be parsed to ASCII characters '0' 'A' '0' '1' as the software version. INFO\_SOFTWARE\_VER constant is defined as 83.

Command **CCP\_FLASH\_READ**

Length 3

data[0] 0xF2

data[1] CAL\_TPS\_DEAD\_ZONE\_LOW

data[2] 1

Controller response

Length 1

data[0] TPS\_Dead\_Zone\_Low

Description: Getting controller's Throttle low-end dead zone. CAL\_TPS\_DEAD\_ZONE\_LOW constant is defined as 4.

Command **CCP\_FLASH\_READ**  
 Length 3  
 data[0] 0xF2  
 data[1] CAL\_BRAKE\_DEAD\_ZONE\_LOW  
 data[2] 1

Controller response

Length 1  
 data[0] Brake\_Dead\_Zone\_Low

Description: Getting controller's Brake low-end dead zone. CAL\_BRAKE\_DEAD\_ZONE\_LOW constant is defined as 5.

Command **CCP\_FLASH\_READ**  
 Length 3  
 data[0] 0xF2  
 data[1] CAL\_TPS\_DEAD\_ZONE\_HIGH  
 data[2] 1

Controller response

Length 1  
 data[0] TPS\_Dead\_Zone\_High

Description: Getting controller's Throttle high-end dead zone. CAL\_TPS\_DEAD\_ZONE\_HIGH constant is defined as 38.

Command **CCP\_FLASH\_READ**  
 Length 3  
 data[0] 0xF2  
 data[1] CAL\_BRAKE\_DEAD\_ZONE\_HIGH  
 data[2] 1

Controller response

Length 1  
 data[0] Brake\_Dead\_Zone\_High

Description: Getting controller's Brake high-end dead zone. CAL\_BRAKE\_DEAD\_ZONE\_HIGH constant is defined as 39.

Command **CCP\_A2D\_BATCH\_READ1**

Length 1  
 data[0] 0x1b  
 Controller response  
 Length 5  
 data[0] Brake A/D  
 data[1] TPS A/D  
 data[2] Operation voltage A/D  
 data[3] Vs A/D  
 data[4] B+ A/D

Description: Data batch reading.

- 1) For operation voltage, B+, A/D value and voltage mapping relation is:  
 $V = V_{ad} / 1.84$ . (For 120V controller).  
 $V = V_{ad} / 1.39$ . (For 144V controller).
- 2) Vs is defined as the 5V power supply for Hall sensor, control panel, ect. A/D value and voltage mapping relation is: 120 ~ 134 mapping to 4.75 ~ 5.25V.
- 3) Brake and TPS are defined as the Brake and the Throttle analog input. A/D value and voltage mapping relation is: 0 ~ 255 mapping to 0 ~ 5V.

Command **CCP\_A2D\_BATCH\_READ2**

Length 1  
 data[0] 0x1a  
 Controller response  
 Length 6  
 data[0] Ia A/D  
 data[1] Ib A/D  
 data[2] Ic A/D  
 data[3] Va A/D  
 data[4] Vb A/D  
 data[5] Vc A/D

Description: Data batch reading.

- 1) For Va, Vb, Vc, A/D value and voltage mapping relation is:  
 $V = Vad / 1.84$ . (For 120V controller).  
 $V = Vad / 1.39$ . (For 144V controller).
- 2) Ia, Ib and Ic are defined as the three phase current.

Command **CCP\_MONITOR1**

Length 1  
 data[0] 0x33  
 Controller response  
 Length 6  
 data[0] PWM  
 data[1] enable motor rotation  
 data[2] motor temperature  
 data[3] Controller's temperature  
 data[4] temperature of high side FETMOS heat sink  
 data[5] temperature of low side FETMOS heat sink

Description: Data batch reading.

- 1) PWM is output duty cycle, from 0 to 100.
- 2) data[1] indicates enabling motor rotation or disabling. 1 - enable, 0 - disable.
- 3) data[2] is defined as the temperature of motor in Celsius temperature. If the temperature sensor is not connected, the controller returns 0xFF.
- 4) data[3]-data[5] are defined as controller inside temperature in Celsius temperature. The value of data[4] and data[5] are inaccurate below 30°C.

Command **CCP\_MONITOR2**

Length 1  
 data[0] 0x37  
 Controller response  
 Length 5  
 data[0] MSB of mechanical speed in RPM  
 data[1] LSB of mechanical speed in RPM  
 data[2] present current accounts for percent of the rated current of controller  
 data[3] MSB of error code  
 data[4] LSB of error code

Description: Data batch reading.

- 1) Mechanical speed calculation:  $(MSB \ll 8) | LSB$ . If the speed out data is not match the real speed value, please configure the motor poles calibration data of the controller based on the driven motor.
- 2) Controller error status:  $(data[3] \ll 8) | data[4]$ ,

data[3]M	7	6	5	4	3	2	1	0	data[3]L
	0x44	0x43	0x42	0x41	0x34	0x33	0x32	0x31	
data[4]M	7	6	5	4	3	2	1	0	data[4]L
	0x24	0x23	0x22	0x21	0x14	0x13	0x12	0x11	

if(data[3] << 8) | data[4]=0x4008,The corresponding error code is 0x43and 0x14.

Command **COM\_SW\_ACC**

Length 2

data[0] 0x42

data[0] COM\_READING

Controller response

Length 1

data[0] Current throttle switch status

Description: Getting Throttle switch status, 1 – active, 0 – inactive. COM\_READING constant is defined as 0.

Command **COM\_SW\_BRK**

Length 2

data[0] 0x43

data[0] COM\_READING

Controller response

Length 1

data[0] Current Brake switch status

Description: Getting Brake swith status, 1 – active, 0 – inactive. COM\_READING constant is defined as 0.

Command **COM\_SW\_REV**

Length 2

data[0] 0x44

data[0] COM\_READING

Controller response

Length 1

data[0] Current Reverse switch status

Description: Getting Reverse swith status, 1 – active, 0 – inactive. COM\_READING constant is defined as 0.

#### **NOTICE:**

1.CAN bus rate should be configured to 1Mbit/s.

2.If the command is out of above commands

Controller response

Length 1

data[0] CCP\_INVALID\_COMMAND

Description: CCP\_INVALID\_COMMAND constant is defined as 0xe3.

## Contact Us:

**Kelly Controls, LLC**

**Home Page:**

<http://www.KellyController.com>

**E-mail:**

[Support@KellyController.com](mailto:Support@KellyController.com)

**Phone:**

(01) 224 637 5092